



Fire Protection  
Association®



# RC62: Recommendations for fire safety with PV panel installations

The Joint Code of Practice for fire safety with  
photovoltaic panel installations, with focus on  
commercial rooftop mounted systems



MCS

**RISK INSIGHT, STRATEGY AND CONTROL AUTHORITY**  
REDUCING INSURABLE RISK THROUGH RESEARCH, ADVICE AND BEST PRACTICE

Version 2 Published 2023

## IMPORTANT NOTICE

---

This document has been developed through RISC Authority and published by the Fire Protection Association (FPA). RISC Authority membership comprises a group of UK insurers that actively support a number of expert working groups developing and promulgating best practice for the protection of people, property, business, and the environment from loss due to fire and other risks. The technical expertise for this document has been provided by the technical directorate of the FPA, external consultants, and experts from the insurance industry who together form the various RISC Authority Working Groups. Although produced with insurer input it does not (and is not intended to) represent a pan-insurer perspective. Individual insurance companies will have their own requirements which may be different from or not reflected in the content of this document.

FPA has made extensive efforts to

check the accuracy of the information and advice contained in this document, and it is believed to be accurate at the time of printing. However, FPA makes no guarantee, representation, or warranty (express or implied) as to the accuracy or completeness of any information or advice contained in this document. All advice and recommendations are presented in good faith on the basis of information, knowledge, and technology at the date of publication of this document.

Without prejudice to the generality of the foregoing, FPA makes no guarantee, representation or warranty (express or implied) that this document considers all systems, equipment and procedures, or state of the art technologies current at the date of this document.

Use of, or reliance upon, this document or any part of its content is voluntary, and is at the user's own risk. Anyone

considering using or implementing any recommendation or advice within this document should rely on his or her own personal judgement or, as appropriate, seek the advice of a competent professional and rely on that professional's advice. Nothing in this document replaces or excludes (nor is intended to replace or exclude), entirely or in part, mandatory and/or legal requirements howsoever arising (including, without prejudice to the generality of the foregoing, any such requirements for maintaining health and safety in the workplace).

Except to the extent that it is unlawful to exclude any liability, FPA accepts no liability whatsoever for any direct, indirect, or consequential loss or damage arising in any way from the publication of this document or any part of it, or any use of – or reliance placed on – the content of this document or any part of it.

**Note on drafting:** Within this Joint Code of Practice, the word ‘must’ identifies a compulsory procedure. The word ‘shall’ indicates a mandatory requirement, except where compliance is impractical, in which case a written risk assessment is required. The word ‘should’ identifies a procedure that is recommended best practice.

---

This document has been developed as a Joint Code of Practice by RISC Authority and the Microgeneration Certification Scheme (MCS), with the support of Solar Energy UK. It is published by the Fire Protection Association (FPA).

The technical expertise for this document has been provided by the Technical Directorate of the FPA, MCS PV Working Group Members, and Solar Energy UK. Although produced with insurer input, this JCoP does not (and is not intended to) represent a pan-insurer perspective. Individual insurance companies will have their own requirements, which may be different from or not reflected in the content of this document.

The FPA and MCS have made extensive efforts to check the accuracy of the information and advice contained in this document, and it is believed to be accurate at the time of printing. However, FPA/MCS make no guarantee, representation, or warranty (express or implied) as to the accuracy or completeness of any information or advice contained in this document. All advice and recommendations are presented in good faith based on information, knowledge, and technology as at the date of publication of this document.

Without prejudice to the generality of the foregoing, neither FPA nor MCS make any guarantee, representation, or warranty (express or implied) that this document considers all systems, equipment, and procedures or state-of-the-art technologies current at the date of this document.

Use of, or reliance upon, this document, or any part of its content, is voluntary and at the user’s own risk. Anyone considering using or implementing any recommendation or advice within this document should rely on his or her own personal judgement or, as appropriate, seek the advice of a competent professional and rely on that professional’s advice. Nothing in this document replaces or excludes (nor is intended to replace or exclude), entirely or in part, mandatory and/or legal requirements howsoever arising (including without prejudice to the generality of the foregoing any such requirements for maintaining health and safety in the workplace).

Except to the extent that it is unlawful to exclude any liability, neither FPA nor MCS accept liability whatsoever for any direct, indirect, or consequential loss or damage arising in any way from the publication of this document or any part of it, or any use of, or reliance placed on, the content of this document or any part of it.

---

#### **A note from the sponsors and contributors**

RISC Authority membership comprises a group of UK insurers that actively support a number of expert working groups developing and promulgating best practice for the protection of people, property, business, and the environment from loss due to fire and other risks.

---

#### **About the Microgeneration Certification Scheme (MCS)**

MCS creates and maintains the standards for small-scale renewable technologies and the contractors who install them. As such, the standards for solar PV are a core part of the MCS remit – helping to define what safe, competent, and high-quality solar installation looks like.

*“We envisage that this new edition of RC62 will help solar contractors to safeguard against and mitigate fire risk at all stages of an installation. By working alongside the FPA and SEUK to realise these changes, we have been able to ensure that the industry continues to represent its own needs and ultimately provides consumers with the reassurance that safety is paramount when it comes to solar.”*

### About Solar Energy UK (SEUK)

Safety is the number one priority of the UK solar industry.

Solar Energy UK members are committed to driving the highest possible standards across the sector, and this updated edition of RC62 will help to ensure that. The solar industry welcomes clarity on how to minimise fire risk from solar PV systems, which in absolute terms is extremely low.

*"The core way to mitigate any risk is to ensure the highest possible quality in the design, installation, operation, and maintenance of solar systems. This document describes and explains how to do that, drawing on developments in risk control measures adopted by the UK solar industry in recent years. These measures notably include adherence to relevant standards from bodies including the Institution of Engineering and Technology(IET).*

*"The commercial rooftop solar industry is poised for significant growth in the UK, as businesses turn to onsite generation to provide financial stability and reduce their climate impact. This new edition of RC62 means they and their insurers can have confidence in their systems, knowing they have been installed based on the most up-to-date practices possible.*

*"As such, we endorse and recommend that the insurance industry uses this new edition of RC62 as a guide to fire risk prevention in UK solar systems."*

### Acknowledgements

The assistance of James Hoare of LHW Partnership LLP in the preparation of this document, is gratefully acknowledged.

# Contents

Foreword . . . . .	4
Summary of key fire risk management . . . . .	5
Glossary . . . . .	7
<b>1</b> Introduction . . . . .	10
<b>2</b> Scope . . . . .	11
<b>3</b> Synopsis . . . . .	12
<b>4</b> Types of PV Systems and main differences . . . . .	12
<b>5</b> Recommended mitigation and protection measures . . . . .	13
<b>6</b> Checklist . . . . .	26
Appendix 1 Principal Sector Technical Standards and guidelines	35
Appendix 2 PV System Components and Electrical Fires . . . . .	37
Appendix 3 PV System Components (Principal) . . . . .	38
Appendix 4 References . . . . .	41
Appendix 5 The Equivalent Circuit of a PV Panel or String . . . . .	44
Appendix 6 Example issues and losses . . . . .	46

# Foreword

Globally, PV is one of the fastest growing, most reliable, and most adaptable forms of electricity generating technology available. In the UK, PV is now generally economically viable at scales from residential projects through to large utility-scale projects, without the need for subsidy. In many locations – particularly urban areas – PV is probably the most feasible localised electricity generation technology available for adoption.

The incidence of fires involving PV systems is very low. However the addition of a PV system which is not correctly designed, installed, or maintained could – like any electrical service – add to the overall risk of fire. As the installation and use of such systems increases, the number of incidents may also increase, especially if systems are not designed and installed to the relevant standards or they are not regularly and properly maintained. This revised RC62 document has been prepared to provide an updated practical guide for insurers and their clients on the requirements for the procurement, ownership, operation, and maintenance of safe and efficient PV systems. The focus of the recommendations in this document are on larger commercial and industrial rooftop PV systems but much of the guidance has relevance to PV systems in general.

The Fire Protection Association (FPA), RISC Authority, Microgeneration Certification Scheme (MCS), and Solar Energy UK (SEUK) have worked together to develop this freely-available update to the original RC62 document: Recommendations for fire safety with photovoltaic panel installations (first published in 2016). The rewrite is jointly funded by the FPA and MCS.

The primary focus of this Risk Control (RC) document is the prevention and mitigation of fires involving PV systems. The Code applies to all stages of a project: planning, procurement, design, installation, operation, and maintenance. With the exception of some niche applications, the scope relates to roof-top installations on commercial and multi-residential buildings up to and including larger utility-scale projects. The recommendations in this guide are not intended for single residence dwellings (detached or connected), or to roof-integrated PV panel systems, i.e. those where the PV panels form part of the building envelope. While commercial ground-mounted PV systems are not covered in detail in this guide, the risk control principles discussed are similar.

Hazards to PV installations other than fire – such as theft and flood – are mentioned for awareness but not covered in detail in this guide.

The following publications are considered essential reading in conjunction with this document, providing more specific details of the requirements:

- MIS3002 *The Solar PV Standard (Installation)*
- IET *Code of Practice for Grid-connected Solar Photovoltaic Systems* (referred to within this document as the IET PV Code of Practice)
- BS EN 62446-1:2016 *Photovoltaic (PV) systems – Requirements for testing, documentation and maintenance – Part 1: Grid connected systems – Documentation, commissioning tests and inspection*
- BS EN IEC 62446-2:2020 *Photovoltaic (PV) systems – Requirements for testing, documentation and maintenance – Part 2: Grid connected systems – Maintenance of PV systems*
- IEC TR 63226:2021 *Managing fire risk related to photovoltaic (PV) systems on buildings*
- SEUK Operation and Maintenance publications.

# Summary of fire risk management

This document has been developed through RISC Authority, Solar Energy UK (SEUK), and MCS. It is published as a Joint Code of Practice (JCoP) by the Fire Protection Association (FPA) and the Microgeneration Certification Scheme (MCS). RISC Authority membership comprises a group of UK insurers that actively support a number of expert working groups developing and promulgating best practice for the protection of people, property, business, and the environment from loss due to fire and other risks. The MCS and SEUK working groups consist of expert practitioners (designers, installers, manufacturers, and consumer experts) with many years' experience delivering safe PV installations. The table below summarises the key points of the document.

<p><b>Understand that PV system installations range in size, are installed in a diverse range of locations, and have a diverse range of owners</b></p>	<ul style="list-style-type: none"> <li>• PV systems are scalable, from just a few modules up to many thousands of modules. They are suitable for roof top mounting as well as large field-based ground-mounted applications and can have a variety of ownership models. This diversity of contexts leads to a wide range of insurability issues, with varying risks and requirements depending on location and ownership.</li> <li>• Wall-based PV cladding and façade systems are specialist systems with particular insurance requirements, and require additional guidance not contained in this document.</li> </ul>
<p><b>Plan ahead and comply with national and industry specific requirements and standards, and good practice</b></p>	<ul style="list-style-type: none"> <li>• Statutory regulations, along with mature and maintained industry technical regulations and standards, are available to facilitate both legal compliance and good risk management of PV systems.</li> <li>• A review of recent publications on the subject of PV and fires (P100874-1000, 2017) outlined over 180 UK and international publications; the large quantity of available documentation risks diluting the topic focus. The UK has well-developed, mature, and maintained technical standards and codes of practice, linked to recognised international standards, that detail the requirements controlling the risk of fire from PV systems.</li> <li>• Some international organisations involved with PV projects in the UK mandate standards that may contain variant requirements. This is acceptable but must be conditional on primary compliance with UK legislation and technical standards purposefully developed for the UK market.</li> </ul>
<p><b>Engage with relevant stakeholders</b></p>	<ul style="list-style-type: none"> <li>• From an early stage, identify, consult, and involve relevant stakeholders in the proposed project. This will provide clarity and determine the exact requirements for the project.</li> </ul>
<p><b>Consider system design and installation</b></p>	<ul style="list-style-type: none"> <li>• Correct design, equipment selection, inspection, and installation are fundamentally important in minimising the risk of losses from PV fires.</li> <li>• Issues associated with installation have been identified as the largest single cause of PV fires. A study undertaken by the Building Research Establishment (BRE) in 2017 identified PV DC connectors, inverters, and DC isolators as accounting for 84% of PV system related fires (P100874-1004, 2017).</li> </ul>
<p><b>Consider inspection, testing, commissioning, and handover</b></p>	<ul style="list-style-type: none"> <li>• Product failure has been identified as the second largest cause of PV fires. Correct installation, inspection, and verification that the products installed are compliant – together with rigorous testing and commissioning – will reduce the potential for product failure and fire risk.</li> <li>• Good handover and communication of the details of the PV system (both in hard copy or read-only electronic and conveyable form), along with operational training and inductions, will aid system owners'/stakeholders' understanding of the PV system. This will allow early identification of any performance changes or unusual observations which may indicate that a more serious issue is imminent.</li> </ul>

<p><b>Anticipate potential external influences on an ongoing basis</b></p>	<ul style="list-style-type: none"> <li>• The PV system itself may not change in the 25–35 year life expectancy, but factors including tree growth, vegetation growth, lichen growth, the rollout of roof-mounted 5G telecoms masts, nesting birds, new third party construction, and other changes can significantly influence and alter the PV system characteristics from the original design. This may increase the fire risk.</li> <li>• The frequency of more extreme weather conditions – including increased precipitation, flooding, and long periods of hot or cold temperatures – is expected to increase in the future. This could affect the fire safety of PV systems.</li> </ul>
<p><b>Understand system operation and maintenance requirements</b></p>	<ul style="list-style-type: none"> <li>• Routine and regular maintenance can help to mitigate any risks which may arise or increase over time.</li> <li>• Knowledge of correct PV system operation is fundamentally important, allowing early identification of potential issues. All PV systems require a level of routine and preventative inspection and maintenance.</li> <li>• Manage vegetation, and clean PV panels (particularly where there is an excessive build-up of dirt, algae, moss or lichen) to maintain product longevity and reduce the risk of fire caused by the PV system.</li> <li>• Check/inspect PV systems at least annually.</li> </ul>
<p><b>Provide training and increase awareness</b></p>	<ul style="list-style-type: none"> <li>• In order to manage the fire risk of existing PV installation assets, and to accommodate the significant projected growth in the number of installations, there is an emerging need for harmonised, disciplined, and robust training and recognised competencies for system maintenance, underwritten by recognised authorities.</li> </ul>
<p><b>Embrace technology development</b></p>	<ul style="list-style-type: none"> <li>• Emerging and adapted product/service innovations – for example, in areas such as artificial intelligence (AI) for fault prediction, or miniaturisation and simplification of UAV (unmanned aerial vehicle, aka drone) technology for inspection work – will improve the ability to manage the growing PV asset more effectively.</li> </ul>



# Glossary

## **AC**

Alternating current. Electricity delivered to locations/premises in the form of a current that follows a waveform alternating from a positive to a negative value about 50 times each second.

## **Above roof PV system**

An installation where the solar panel is mounted above the roof covering and the installation kit does not replace or significantly alter the roof covering beneath it.

## **Arcing**

A type of electrical flashing or discharge that results from a connection through air to ground or to another voltage phase in an electrical system. Temperatures and energy transfer at the source of an arc flash can reach 20,000 °C.

## **BIPV**

A BIPV (building-integrated photovoltaic) product is tailored and manufactured to a specific project, with a size, shape, and configuration particular to that project. For the purposes of this document, a BIPV product is defined as being a PV unit manufactured in varying sizes and configurations for the sole purpose of being built into the fabric of a structure – such as PV glazing, PV façade units or PV shading units.

## **BSI**

The British Standards Institution (BSI) is the national standards body of the United Kingdom. BSI produces technical standards relating to a wide range of products and services; it also supplies certification and standards-related services to businesses.

## **Building Fire Load**

The term 'Building Fire load' is used to describe the potential severity of a fire within a specified space. It is therefore a form of hazard assessment, used to determine the level of fire risk that exists within a defined area.

## **CAA**

Civil Aviation Authority

## **DC**

Direct current is a unidirectional flow of electricity, commonly associated with batteries as well as PV panels. At a given voltage, DC current presents a greater threat to life than AC current.

## **Galvanic corrosion**

An electrochemical process that occurs as a result of the flow of very small electric currents between two dissimilar metals, causing the more anodic metal to corrode while the noble/cathodic metal is not affected. Also known as bimetallic corrosion. Relevant for PV connector compatibility.

## **IEC**

The International Electrotechnical Commission is an international organisation that prepares and publishes international standards for all electrical, electronic, and related technologies (electrotechnology).

## **IET**

Institution of Engineering and Technology

**Inverter**

A component that converts DC current to AC current in a form suitable for supply to premises and to the electricity distribution network.

**Low voltage**

A voltage not exceeding:

- 1000 volts AC or 1500 volts DC if measured between any two conductors
- 600 volts AC or 900 volts DC if measured between a conductor and earth.

**LPS**

Lightning protection system.

**MC4**

The globally preferred PV connector for interconnective PV module strings and inverters.

**MCS**

The Microgeneration Certification Scheme, which defines and maintains standards for a range of small-scale renewable technologies, including solar PV.

**MLPE**

Module-level power electronics are devices for DC-DC or DC-AC conversion at the module level, which can limit DC voltages close to the modules in the event of a fault.

**Ofgem**

The UK energy regulator, which manages PV Feed-In Tariffs, Renewables Obligation Certificates (ROCs), and other subsidy schemes.

**PID**

Potential induced degradation reduces the power output from a PV cell/module and allows shunt currents to flow from earth to the cell.

**PV**

An abbreviation for Photovoltaic, Solar PV or Solar Power, or the conversion of light into electricity. This document uses the term PV system to refer to a complete solar PV system.

**Riso**

The measured insulation resistance from the PV side DC conducting components in a PV system to ground/earth.

**Roof integrated PV system**

An installation where the solar panel or roof mounting system (or an individual component of a roof mounting system) replaces some or all of the roof covering (i.e. forms part of the building envelope).

**Rs**

Series resistance. The resistance of resistive elements in a PV module or string that are in electrical series with the main current flow to the inverter.

**Rsh**

Shunt resistance. The parallel resistance in a PV module, that provides an alternative path for generated electricity out of the cable connections.

**SEUK**

Solar Energy UK - the largest PV sector trade association.

**Wp**

Watt peak. The internationally recognised metric measurement for a PV panel. SI unit factors are kWp (×1000), MWp (×1,000,000), and GWp (×1,000,000,000).

# 1 Introduction

- 1.1 Globally, PV is one of the fastest growing, most reliable, and most adaptable forms of electricity generating technology available. In the UK, PV is now generally economically viable at scales from residential projects through to large utility-scale projects, without the need for subsidy. In many locations – particularly urban areas – PV is probably the most feasible localised electricity generation technology available for adoption.
- 1.2 PV systems range from residential roof mounted systems, secured to the roof structure by mechanical fixings or by non-penetrating ballast, through to large ground mount systems where the panels are mounted on table racks/frames. In all systems, the PV panels generate DC electricity that is converted to AC via power inverters, either for local consumption or for export to the grid. Typically, PV systems are connected to the electricity distribution network at low voltage (230/400 V); in the case of larger systems, the energy may be transformed up for connection to the distribution network at higher voltages.
- 1.3 New roof mounted PV installations shall be installed on purpose-built mounting systems to support the equipment. Systems installed on pitched roof systems are mostly mechanically fixed to the underlying roof structure; the arrangements for doing this need to be weathertight and leak-proof. Systems installed on flat roofs are mostly bonded or ballasted. Such systems avoid issues around weather-tightness but can be problematic if the roof structure deflects under the weight of ballast: deflection can lead to rainwater pooling, which will add weight to the roof and may cause the roof loading to exceed its design capacity which, in the worst case, may lead to a collapse.
- 1.4 By the nature of the function of the technology, a large proportion of a PV system is exposed to the external elements and over a year will be required to operate within a range of environmental extremes and day/night thermal duty cycles. Typically, the UK could be subjected to temperatures ranging from  $-15^{\circ}\text{C}$  to  $40^{\circ}\text{C}$ ; icy, wet and dry conditions; winds up to 160kph (100mph); and low to high humidity. It is a realistic expectation that the UK will experience more weather extremes in the years ahead.
- 1.5 In the UK, the installed capacity at the outset of the Feed-In Tariff and ROC subsidy schemes (2008) for PV was negligible. However, it has risen consistently year on year to an estimated 18 GWp of installed capacity today. This equates to an estimated 50 million installed PV modules. Current estimates indicate that, to align with International CO<sub>2</sub> reduction commitments, the UK will require an installed PV capacity of circa 40 GWp by 2040. This will necessitate a significant increase in the number of installations of all sizes; it is also likely that a large proportion of new building projects will incorporate PV.
- 1.6 In daylight, unless the PV modules are shielded from light entering the panels, there will be potentially harmful voltages present even if the system is not operational.
- 1.7 All electrical systems require the presence of current flows, voltage potential, and electric fields. PV systems are no different. There is also a combination of electrical insulating and conducting materials present in such systems. The weakening and failure of insulating and conducting materials has been the primary cause of the majority of electrical fires since the invention of electricity.
- 1.8 PV systems are essentially silent and generally benign but they do present hazards which are not immediately obvious to owners and firefighters called to the premises. There have been several recorded fires where concerns have been raised by firefighters regarding electrical safety. Such concerns could prompt the use of defensive preventative firefighting tactics, whereby the fire is prevented from spreading to nearby properties rather than being extinguished at its source. This approach could result in significant property losses.

- 1.9 Historically, electrical power generation has involved rotating machinery. Rotating machine generators have fewer sub-components than PV systems but these components are susceptible to wear and deterioration. A PV system may have hundreds or thousands of electronic sub-components but, as they are 'solid-state', these components are less vulnerable to wear. Therefore, the reliability of PV systems is very high, resulting in a low frequency of documented fires. However, when the numbers of existing and planned PV systems are considered, even with a very high reliability and low failure rate, the potential for PV fires remains significant.
- 1.10 The solar industry has been well managed with compliance requirements for subsidy enabled schemes, either via the Microgeneration Certification Scheme (MCS) or Ofgem. As the era of subsidy free PV system installation has arrived, there is a need for strong adherence to robust recognised standards and guidelines for the benefit and safety of all stakeholders. The MCS, Institution of Engineering Technology (IET), and Solar Energy UK have provided managed standards, technical good practice guides, and requirements that carefully incorporate mandated UK and international standards, combined with shared experience-based knowledge.
- 1.11 This guide seeks to provide reference to existing relevant regulations and guidelines as applicable to PV installations, to provide an overarching reference point for insurers and their clients. It will also provide practical guidance for insurers and their clients for the procurement, ownership, and operation of safe and efficient PV systems, encompassing and embracing good practice guidelines from the PV industry, both for PV systems themselves and for wider exposure issues that could lead to insurance claims.

## 2 Scope

- 2.1 This document aims to provide practical guidance to insurers and their clients on the requirements for the procurement, ownership, operation, and maintenance of safe and efficient PV systems to ensure good risk control practice and fire hazard management. These recommendations focus on all PV system applications (subject to scope consideration presented in the Foreword to this guide), including industrial, commercial, public sector, and utility scale systems where consideration is being given to the installation of a PV system. This encompasses both retrofits undertaken after the completion of an original installation and new installations, as well as extensions to existing PV system installations. The measures are also generally applicable to free-standing arrays of panels located on open ground.
- 2.2 Though the core technology is the same, there are often notable differences between rooftop and ground mount PV systems. Rooftop systems are generally on top of buildings that are occupied, whereas ground mount systems are typically large and affixed directly to the ground, generally with few people in close proximity. Ground mount systems often have high voltage equipment to connect to the electricity distribution network, with additional complexity and risks. Rooftop and ground mounted systems present different challenges in terms of fire safety, technical compliance, and operational and maintenance requirements.
- 2.3 These recommendations address fire hazards and aspects relating to PV installations, as well as issues which may lead to other forms of loss or may pose a threat to firefighters. It is a fundamental requirement that systems are designed and installed to recognised technical standards and key components are certified to recognised standards.
- 2.4 This document does not cover PV cladding or façade systems, or roof integrated systems, where the insurability requirements are currently complex and more specialist.
- 2.5 This document does not cover battery energy storage systems (BESS), which are a synergistic technology providing a constant energy supply from variable sources of energy such as solar power. Nor does it specifically cover floating solar or concentrating PV systems. These require specialist consideration. Refer to RISC Authority 'Need to Know Guide RE1: Battery Energy Storage Systems (BESS) – Commercial Lithium-ion Battery Installations.

## 3 Synopsis

- 3.1 The recommendations in this document provide detailed guidance and background information relating to property insurance expectations concerning the installation of PV systems on commercial, industrial, public sector, and community owned buildings.
- 3.2 Consideration is given to recommendations for the location and fitting of panels on buildings, and aspects of electrical safety, where this has an impact on the prevention of fires and the associated insurability.
- 3.3 There are prescriptive and mature technical standards available; these recommendations make clear reference to these standards but the exact wording has not been reproduced in this document. Relevant stakeholders should access these standards as needed.
- 3.4 Mitigation of the threat to life is addressed in addition to property protection, in as much as guidance is given regarding the safety of firefighters, particularly from electrical hazards associated with the DC side of the installation. Business interruption factors are also considered.
- 3.5 Emphasis is placed on the need for PV systems – including free-standing arrays of panels – to be correctly planned, carefully designed, correctly installed by trained and competent technicians, and operated and maintained in accordance with good practice guidelines.
- 3.6 The PV industry is maturing yet growing rapidly. It is also receptive to technological innovation, from both within and without the sector; this may improve the inherent safety of PV systems in the years ahead. Examples include artificial intelligence and the use of miniaturised UAVs for inspection.

## 4 Types of PV system and main differences between them

- 4.1 There are two principal types of PV system: roof top and ground mount systems. Rooftop systems range in size from a few PV modules (1 kWp) on a single dwelling, up to 5 MWp (several thousand PV modules) on larger warehouse-type applications. Ground mount systems can range from a few kW up to several hundred MW and can cover huge expanses of land.
- 4.2 There are other more niche PV system applications, including facades, BIPV and glass-glass laminates. Such niche specialist installations are not considered in this document; however, they should generally be installed applying the risk control principles covered in this document.
- 4.3 Typical public and commercial PV system owners are schools, commercial offices, industrial businesses, public sector organisations, farmers, estates and landowners, utilities and financial organisations.
- 4.4 There are thousands of small remote battery-based solar systems for signage and illumination etc. However, the majority of PV systems are connected to the electricity distribution network.
- 4.5 Rooftop PV systems are affixed to roofs with mechanical fixings, or with ballast, whereas ground mount systems are mounted on racks that are generally piled in the ground.
- 4.6 The majority of rooftop based systems are connected at 240/400 V (low voltage). Larger scale PV farms are generally connected at high voltage (HV) and so require additional HV equipment including transformers, with increased complexity and risks. Some larger roof mounted systems may also be connected at HV.

- 4.7 Rooftop PV systems are elevated at height, so the risk of flooding impact is negligible. Ground mount systems are generally located on lower grade agricultural or brownfield sites that may be susceptible to flooding. As a general rule, ground mount PV installations should not be installed in areas with moderate to high flood risk unless specific measures are taken to protect the PV array and electrical systems from water (such as using an elevated mounting system). In all cases, flood surveys should be carried out to ensure that sites proposed for ground mount PV installations are suitable.
- 4.8 Theft of equipment from rooftop systems, though achievable, is made difficult due to the height of the equipment and the fact that most buildings with this type of system are occupied. Ground mount solar systems are often located remotely and the sites are predominantly unmanned, which makes these sites more vulnerable to theft. Refer to RISC Authority S33 *Solar farm security* for theft protection guidance.
- 4.9 PV systems may be owned by a party separate from the building owner, landowner or tenant where the PV installation is located. It is important that such installations follow the same risk control measures as those owned and operated by site and landowners or leaseholders.
- 4.10 Floating solar, PV cladding systems, wall mounted systems, solar concentrators (electric or thermal), PV trackers, and hybrid solar hot water/PV systems, are currently a minority of the installed capacity in the UK and not specifically covered in this document.

## 5 Recommended mitigation and protection measures

Many of the recommendations in the following sub-sections – e.g. use of sprinkler systems – are good practice where any electrical installations are present; they are not particular or exclusive to PV.

### 5.1 Compliance with fire safety legislation

- 5.1.1 For every relevant PV project to which the Regulatory Reform (Fire Safety) Order 2005 (or equivalent legislation in Scotland and Northern Ireland) applies, an appropriate fire risk assessment shall be carried out and recorded by a competent person. The risk evaluation will identify the potential risks, the appropriate mitigating measures, and requirements in order to reach the intended fire safety level. A new Fire Safety Act 2021 came into effect on 16 May 2022.
- 5.1.2 Actions should include:
  - i. When required, discuss with the local fire authority in advance. This is important as the fire authority will be responsible for dealing with any fire event and there may be particular project-specific issues – for example, time for responders to reach the fire, or roof access – that may influence the localised fire safety requirements.
  - ii. Discuss the project with the current/prospective building/site property insurer. The insurer may have requirements ranging from organisational policy to knowledge of the building, the contents, and the insurable value. Ownership of the building and ownership of the PV system should be determined, as the owners may not be the same.
  - iii. A historic or heritage building – for example, a cathedral or National Trust, English Heritage, Historic Scotland, CADW, or Landmark Trust building – may require additional, context-specific fire protection measures. Any particular additional requirements should be identified in advance.
  - iv. Gain consensus as to whether the selected site/rooftop is the optimal location for the addition of a PV system, or whether another location may simplify and reduce the risks of a fire and the response in the event of a fire.

- v. Determine whether the existing/proposed roofing materials are suitable for the addition of a PV system and ensure they would not be compromised by impact of stray electrical currents.
- 5.1.3 New rooftop PV installations, including panels and fixing systems, shall not lower the fire performance/classification of the roof. In-roof systems should have the correct fire qualification to satisfy the requirements of the Building Regulations. If installation on a combustible or partly-combustible roof is unavoidable, then a fire resistant covering should be applied.
- 5.1.4 Building Regulations also reference the British Standard BS 5839 6 (also known as BS 5839: Pt. 6) and recommend that a mains powered smoke alarm system is installed if PV/batteries are installed in an attic space.
- 5.1.5 PV panel systems should be selected to have a low propensity for fire spread, with no or minimal propensity to produce burning droplets following ignition. Research is in process to develop a suitable UK fire test specification and standard for property protection, for PV modules. In the meantime, suitability should be based on assessment of fire-classification of (PV modules) materials of construction and available test data (e.g. UL 1703, UL 790, PD CLC/TR 50670:2016, BS EN 61730-2:2007, ASTM E108-20a).
- 5.1.6 Determine whether the addition of DC disconnection switch technology and interfacing with the existing fire systems is mandatory according to UK legislation (BS EN 7671).
- 5.1.7 Subject to risk assessment, determine if the inverter arc fault circuit interrupter is acceptable if fitted and, if not fitted, whether a stand-alone arc fault interrupter is required, mandatory, or not required.
- 5.1.8 Ascertain whether measures for supporting firefighters and first responders will be given consideration, e.g. access, pathways. See section 5.4.4.
- 5.1.9 Some elements of PV installations represent potential sources of ignition and these potential hazards shall be addressed in an assessment (or a review of an existing assessment) under the Dangerous Substances and Explosive Atmospheres Regulations (DSEAR), where appropriate. This applies when a PV panel installation is being planned in an area where a potentially explosive atmosphere may form. The integrity of any existing protected zones should also be reconsidered at this time, especially if electrical equipment will be introduced in a location where previously there was none. Examples include agricultural grain storage barns at harvest time, where the dust could be explosive, and water/chemical processing plants where there can be a build-up of methane or other flammable gases.

## 5.2 Business continuity

- 5.2.1 Fire hazards, and thus the threats to a business, are increased by the need for some processes to continue during the night or over weekends when there are no or few staff present. It is therefore paramount that careful consideration be given to fire safety implications of a PV system that will operate at a fully or partially unattended location when equipment is being specified and the fire risk assessment is undertaken. Refer to RISCAuthority RC42 Fire safety of unattended processes for guidance.
- 5.2.2 Prepare an emergency plan. All organisations should take steps to ensure the continued smooth running of their business by making a suitable emergency plan. Relevant guidance is set out in the RISCAuthority publication Business Resilience: A Guide to Protecting Your Business and Its People. The emergency plan should address the implications for all facets of the business model of a fire, flood, and other perceived loss scenarios. It should indicate lines of communication that should be followed and contact details for specialist assistance.
- 5.2.3 When complete, the emergency plan should be rehearsed by means of an annual tabletop exercise, with the results being assessed and amendments made to the plan as necessary.



- 5.2.4 Consider the applications of commercially available computer programmes to develop and maintain the business continuity plan.

### 5.3 Fire safety management

- 5.3.1 A carefully planned and comprehensive fire safety management regime, observed and embraced by all staff, and coupled with appropriate fire safety routines and adequate staff training, is essential. This cannot be over-emphasised.
- 5.3.2 Unless unavoidable, no hot work (such as welding, flame cutting, and similar activities) shall take place within or adjacent to PV system installations. If, for justified reasons, hot work is necessary, all such activities should be conducted under an effective Permit to Work system and in strict accordance with RISC Authority RC7 *Recommendations for hot work and the RISC Authority Hot Works Site Induction Toolkit*.
- 5.3.3 During the installation process, all waste materials should be tidied and stored safely at the end of each working period.
- 5.3.4 At the commissioning stage, the nominated operator of the system should have the function and control of the system explained to them by the installer. In addition, full details of the system and its operation should be handed over in an appropriate format, to include:
- i. the objectives of regular visual inspections
  - ii. the nature of damage that might be seen following a gale or thunderstorm
  - iii. the cleaning and day-to-day maintenance of the system
  - iv. the need for vigilance to identify damage to cable insulation and overheating of components; and
  - v. the requirement for regular scheduled maintenance.
- 5.3.5 For the purposes of fire risk prevention, the client handover process should include an explanation of the location of emergency isolation measures, and the importance of regular maintenance, bearing in mind this a PV system is an electrical generator.
- 5.3.6 Windblown litter and leaves should not be allowed to accumulate, especially around or beneath PV panels.
- 5.3.7 All installation technicians/engineers should receive suitable instruction when they arrive at the premises as to the sound of the fire alarm and the actions they should take if hearing the alarm or discovering a fire.
- 5.3.8 The possibility of deliberate fire raising from outside the building by intruders, or from within by staff, should not be forgotten. Further advice is provided in RISC Authority RC48 *Arson prevention: The protection of premises from deliberate fire raising*.
- 5.3.9 Automatic fire detection should be installed in all areas inside buildings in which electrical control equipment (inverters, isolators, and distribution boards) is located.
- 5.3.10 As outlined in 5.2.1, when there are no or few staff present, it is paramount that careful consideration be given to the fire safety management implications of a PV system that will operate at a fully or partially unattended location.
- 5.3.11 The installation of fire sprinklers is highly beneficial for the protection of property and should be considered for areas inside buildings where equipment associated with PV systems is installed, as well as for adjacent areas that are exposed by or expose these areas to fire.
- 5.3.12 Care should be taken that obstructions and stored materials do not reduce the level of ventilation provided for the inverters, which can produce significant heat during normal operation.
- 5.3.13 PV installations shall be serviced and maintained in accordance with the installer's instructions and to BS EN IEC 62446-2 (2020). The schedule of maintenance should follow the service contract, warranty conditions, and/or performance guarantees.

## 5.4 Hazard consideration

- 5.4.1 The impact on building fire load of PV systems should be determined and the adequacy of fire protection assessed, especially in areas where PV system equipment has materially increased fire hazard.
- 5.4.2 PV installations should be installed on non-combustible roofs meeting Class A1/A2 s1, d0 to BS EN 13501-1. Fires involving combustible roofs will spread quickly, without the benefit of any protection installed within the building. Adjoining or nearby buildings can potentially also be at risk. See section 5.1.3.
- 5.4.3 The spread of a fire may be accelerated by a chimney effect beneath PV panels, especially on pitched roofs, with heat being radiated back onto the roof from the underside of the panels. The position of the panels may also hinder the opening of the roof to allow ventilation.
- 5.4.4 Consideration should be given to the provision of safe and clear access routes for servicing, maintenance, cleaning, and firefighting operations.
- 5.4.5 High density PV panel covering on roofs may restrict fire fighters from venting and tackling a fire within a building and should be avoided. Guidelines are detailed in IEC TR 63226:2021 section 4.4.3.5.
- 5.4.6 PV panel arrays – particularly ballasted systems – can significantly increase the weight loading on a roof, increasing the potential for a collapse of the roof during a fire. Modern roof designs are often more lightweight, with little tolerance for additional weight other than to satisfy local planning regulations; older roof designs may have deteriorated with age or be in a poor state of repair. A structural survey should be undertaken by a competent person prior to installation, to assess the load bearing capacity of the roof.
- 5.4.7 Ballasted systems may increase the level of water pooling on the roof, due to flexing of the roof structure. A thorough structural review is necessary to ensure collapse hazards are avoided, especially during heavy rainfall.
- 5.4.8 The gaps between the PV panels and the roof can become traps for snow and ice build-up, causing additional issues with accumulation and weight distribution. Drifting snow may also become a problem where there was previously no issue.
- 5.4.9 The gaps between the PV panels and the roof can trap waste debris, foliage, bird/rodent nests etc., and there may be increased growth of moss and lichen to roof areas below panels. These factors can create hot-spots presenting ignition sources, with additional fuel load in direct contact with the PV system.
- 5.4.10 A 'one in a hundred year weather event' impact assessment should be applied when considering the impact of extreme weather. This is increasingly important with the acknowledged change in global weather patterns. Roofs should be inspected after any extreme weather event. Such weather incidences may include:
  - i. Gaps between PV panels and the existing roof are exposed to increased lateral and uplifting forces created by high wind speeds. Systems are designed to accommodate wind speeds of 54 m/s (120 mph), but higher wind speeds have been experienced at exposed higher altitude locations in the UK. Consideration should always be given to the location of the PV system during the design stage.
  - ii. Freak weather conditions that have unusually large hailstones, which have the potential to significantly damage PV modules .
  - iii. Continual heavy rain and sudden storm downpours that can flood areas with PV installations.
- 5.4.11 In addition to the PV panels themselves, there is typically a notable amount of copper and aluminium on a PV installation. This increases the attraction for theft, and there is an expectation of additional security measures proportionate to this risk. There have also been reported incidences of the use of catapults and air rifles to deliberately vandalise PV modules. The risk is higher for commercial and industrial buildings that are closed during weekends and holidays, but reduced where PV systems are not visible from the ground (e.g. flat roofs or shallow-pitched roofs with parapets).

- 5.4.12 Robust on-site controls for staff who access PV installation areas (such as maintenance operatives) should be implemented – e.g. absolutely no smoking (even though the area might be outdoors) and caution with vehicle exhaust systems over long dry grasses.

## 5.5 Design

- 5.5.1 PV system design should incorporate appropriate solutions for minimising risk, especially where design features may have an influence in higher risk settings.
- 5.5.2 All PV installation projects fall under the Construction (Design and Management) Regulations 2015, from small installations up to larger projects. The HSE 'Summary of duties under Construction (Design and Management) Regulations 2015 (CDM 2015)' provides a good overview of client vs contractor duties. <https://www.hse.gov.uk/construction/cdm/2015/summary.htm>
- 5.5.3 For UK projects, the design should be undertaken in accordance with the IET PV Code of Practice and MCS requirements, or equivalent technical requirements for installations outside the UK. It is known that some international operators are mandating other international standards and requirements not referenced in the IET PV Code of Practice and MCS requirements. This is acceptable as the owner's and insurer's choice, provided UK regulations are still met.
- 5.5.4 Clients should ensure that, under the CDM regulations, the design team is competent and sufficiently experienced to be able to design a PV solution to adequately manage and mitigate all risks identified in the risk assessment. If required, additional competence/expertise should be sought to accommodate any skills gaps.
- 5.5.5 RISC Authority RC67 *Recommendations for electrical safety in the event of fire*, provides general risk control guidance for PV systems from LV up to HV. A key aspect is whether the PV system design falls within the BS EN 7671 definition of 'low voltage', as this will impact on the fire safety requirements. This should be determined.
- 5.5.6 BS EN 7671 and the Regulatory Reform (Fire Safety) Order 2005 define 'low voltage' as exceeding 'extra low voltage' but not exceeding 1000 V AC or 1500 V DC between conductors, or 600 V AC or 900 V DC between conductors and earth. Where these voltages can be exceeded, the addition of fire protection is required. In the context of PV systems, the definition of a system as 'low voltage' or 'high voltage' will depend on the individual inverter selected; clarification should be sought from the inverter manufacturer as to how the DC is referenced to the inverter earth, and whether the DC voltage from conductor to earth can be greater than 900 V. If this is the case, then the system would be classified as high voltage and must be designed accordingly. To ensure a PV system is defined as low voltage, it may be possible to design DC module strings to keep the maximum DC voltage between earth and conductor below 900 V; or module level power electronics may be incorporated within the design.
- If the design cannot be classified as 'low voltage', then additional fire protection requirements/mitigations shall be incorporated into the design. Examples of measures include:
- i. Isolation of the DC strings at the modules via a remote switch accessible at a ground level location
  - ii. Use of module level power electronics that switch to 'extra low voltage' when the AC supply is disconnected.
- 5.5.7 Subject to the risk mitigation measures defined by the Fire Risk Assessment, the requirement for adoption or adaptation of lightning protection systems should be reviewed. Changing climatic conditions, with increased humidity and more frequent lightning storms predicted, make exposed metallic framed PV systems vulnerable to lightning strikes. The IET PV Code of Practice outlines the requirements for lightning protection and should be followed. General guidance relating to lightning protection for buildings and structures is available in RISC Authority RC35 *Protection of buildings against lightning strike*. Guidance for lightning protection is also provided in the DTI document *Photovoltaics in Buildings: Guide to the installation of PV systems* (2nd edition).

- 5.5.8 Electrical compliance with BS EN 7671 is a core requirement. Subject to any particular identified risks, the measures including arc suppression, module level power electronics, and DC disconnection systems, should be considered for incorporation into the design to address the mitigation requirements defined by the Fire Risk Assessment.
- 5.5.9 The design should minimise the risk of product failure over the expected design life of the system, not the warranty period alone. This should include the long-term impact of temperature variation, weather, and humidity. Thermal duty cycles and ratings of equipment, especially transformers, should be given correct consideration. A PV system would be expected to have a design life of 30 to 35 years.
- 5.5.10 The PV arrays should not traverse fire barriers or fire walls, and all cabling should be sealed or contained in order to prevent the spread of fire across fire barriers.
- 5.5.11 Components of PV systems often contain combustible materials. In order to effectively limit the spread of fire via components of PV systems, the following measures are necessary (CFPA-E Guideline No 37:2018 F):
  - i. Components of PV systems with combustible elements, e.g. cables, are not allowed to be passed over a compartment/fire wall. If this cannot be avoided, they should be installed in fire-resistant cable ducts and shafts (Figure 5.5.1).

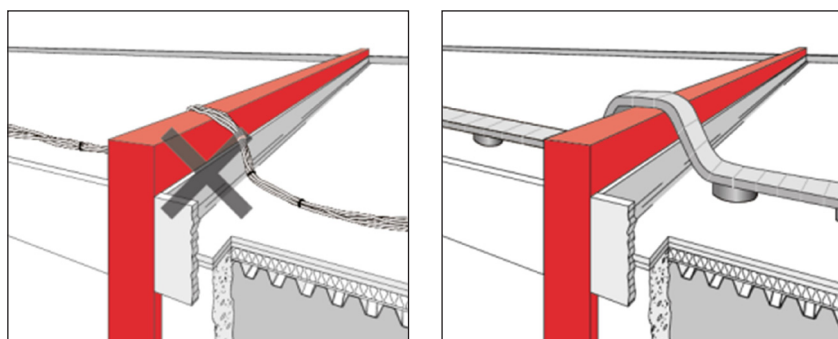

Figure 5.5.1 Conduct of cables in connection with a fire wall. (Images from VdS 2234, reproduced by kind permission of VdS Schadenverhütung GmbH)

- ii. On roofs, there should be a minimum distance of 2.5 m between the PV modules on each side of the compartment/fire walls. A reduced distance is permitted if the potential for a fire to spread across a compartment boundary is considered low (Figure 5.5.2).

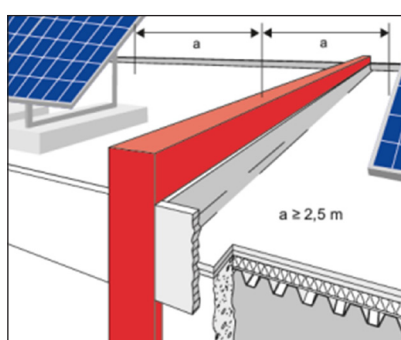

Figure 5.5.2 Arrangement of PV modules on the roof and in connection with a fire wall (Image from VdS 2234, reproduced by kind permission of VdS Schadenverhütung GmbH)

**Note:** Figures 5.5.1 and 5.5.2 show compartment walls that extend through the roof. Similar arrangements shall be used where the compartment wall only extends up to the underside of the building and external fire spread is controlled by fire resisting and non-combustible roof construction, fire stopped where necessary to the top edge of the internal compartment wall. Refer to BDM01 A to Z of Essential Principles for the protection of buildings.

- 5.5.12 For PV installations where the potential for a fire to spread across a compartment boundary is considered low (i.e. all roof elements are non-combustible and PV panel systems have a low propensity for fire spread with no or minimal propensity to produce burning droplets following ignition), a minimum 1.2 m separation between the PV modules on each side of the compartment/fire wall is recommended. This minimum 1.2 m separation on each side of the compartment/fire wall shall also apply for buildings adjoining town-centre retail units and offices where 2.5 m separation on each side of each compartment/fire wall would preclude the feasibility of adding PV systems, and where a spreading fire across multiple buildings is improbable due to other favourable factors.
- 5.5.13 Cable routes and containment should be given careful consideration and mitigation measures put in place to manage DC cable routes within the building that could pose a risk to firefighters in the event of a fire. This should include the DC cable in the areas where PV modules are located, and both external and internal cable routes.
- 5.5.14 Where possible, the internal DC cable route length should be minimal. Where the cables are within occupiable areas, there should be appropriate mechanical protection (e.g. covered cable tray to protect firefighters and other occupants where the PV cables may still be live).
- 5.5.15 Additional fire protection measures will be needed if the roofing material is not PV arc resistant.
- 5.5.16 Rodents, squirrels, and nesting birds (and, for ground mount systems, farm and wild animals) can all cause harm and alter the fire safety properties of a PV system. Consideration should be given to the potential impact, and suitable mitigation measures put in place.
- 5.5.17 The location of the PV inverters and balance-of-system electrical equipment require careful consideration, as typically around 3% of inverter conversion efficiency losses are converted to heat.
- 5.5.18 Eliminate the use of DC isolators wherever possible; many inverters now have integrated isolators).
- 5.5.19 The requirement for when fire detection is required is outlined in section 5.3.9 and the IET PV Code of Practice.



Figure 5.5.3 (left) String cables in tray prior to final cover plate and (right) cable management over parapet wall prior to final cover plate (Reproduced by kind permission of Chris Roberts, Clean Energy Consulting Ltd)

## 5.6 Procurement

- 5.6.1 The procurement process for a PV system, and selection of an appropriate organisation to undertake the installation and operation, are key aspects of any project. An appropriate procurement strategy should be established.

- 5.6.2 The complexities of the project should be reviewed, and potential providers should be selected in the context of those complexities.
- 5.6.3 The MCS document MCS001-1 *The MCS Contractor Standard – Part 1: Requirements for MCS Contractors* provides a comprehensive list of requirements for appropriate contractors, while certification as MCS001-2 *The MCS Contractors Standard – Part 2: The Certification Process* will assist in determining the suitability of contractors.
- 5.6.4 It is recommended that the PV system provider or installation contractor should, as a minimum:
  - i. hold MCS Certification in PV systems and BS EN ISO 9001:2015
  - ii. be an SSIP (Safety Schemes in Procurement) registered member of an organisation, e.g. Acclaim or CHAS
  - iii. hold appropriate certification accreditation and competence for DC, low voltage AC, and (if the project will be HV connected) high voltage systems
  - iv. have membership of environmental schemes (e.g. ISO 14001:2015) and safety schemes (e.g. ISO 45001:2018) – desirable
  - v. hold appropriate insurance including an appropriate level of professional indemnity to cover the scope of the project requirements.
- 5.6.5 Before selecting a provider for the project, it is important to undertake a careful review of previous experience, relevant to the scope of the work. References should also be sought from customers/clients on selected previous projects.
- 5.6.6 In line with CDM 2015 regulations, complete a review of the key staff in terms of experience, competence, and suitability, and review technical CVs. This should include all technical competencies including electrical, mechanical, structural, and civil engineering skills.
- 5.6.7 Undertake a company financial review.
- 5.6.8 In addition to reviewing the lead contractor/installer, it is essential to review the proposed subcontractors with reference to the longevity of lead contractor/subcontractor relationships. Additionally, it is necessary to check what material/equipment will be supplied by the lead contractor or novated to the subcontractors. These checks are important, as it is likely that the work areas of highest potential fire risk will be undertaken by subcontractors.
- 5.6.9 All equipment to be provided shall comply with the relevant technical standards. PV modules should be MCS certified.

## 5.7 Installation

- 5.7.1 All installation work should be in accordance with the requirements of MCS and the IET PV Code of Practice and documents referenced therein (or equivalent if non-UK). Installation teams should hold the prerequisite competence and experience.
- 5.7.2 The installation should be in accordance with the PV system design.
- 5.7.3 Manufacturer's installation instructions should be carefully read, and the installation instructions followed; this includes instructions for DC connectors and isolators as well as inverters and PV modules.
- 5.7.4 Mixing of PV DC connectors from different manufacturers should be avoided, and all panel connections should use the connector(s) recommended by the panel manufacturer. System operators should hold spare PV DC connectors compatible with the PV installation for future maintenance, to avoid the potential use of incorrect PV DC connectors. Internationally documented PV fire loss data identifies faults with DC connectors and DC isolators as primary causes of fire. Therefore, it is essential to use the correct PV DC connector, assembled according to the manufacturer's guidelines, with the correct length and thickness of exposed DC cable, the correct crimping tool for the connector pins, and the correct torquing of the connector cable glands. IEC 62548:2016 and IEC 60364-7-712:2017 explicitly do not allow the connection of DC connectors from different manufacturers.

- 5.7.5 Interim inspections during installation should be undertaken to ensure DC cable in particular is not vulnerable to being pinched beneath PV modules. This type of fault is difficult to detect once the PV modules have been installed and may cause early-stage damage that could take several years to be identified.
- 5.7.6 Care should be taken to ensure the DC connectors lie horizontally and not vertically; vertical orientation facilitates water ingress into the connector via gravity action, allowing water to build up internally. Care should be taken to ensure the DC connectors are positioned off the roof surface and secured to mitigate the risk of water ingress.
- 5.7.7 DC cable runs should be on supported cable management systems, with facility for water draining. Cables should be tied to prevent excessive movement in the wind, but not tied so tightly as to cause stresses.
- 5.7.8 PV modules typically have 1 metre factory-made cable and connectors. This can cause containment challenges when multiple interconnecting PV modules are used together, and care should be taken to avoid any PV module cables sagging, flapping, or lying in areas where there may be a risk of pooling water.
- 5.7.9 Panels and wiring should be located where they are not likely to be damaged by rodents, (and for ground mount systems) sheep, or cattle. In agricultural premises where this is a particular problem, consideration should be given to laying cabling in secure and sealed trunking/ducts. To reduce the likelihood of attack by rodents, sagging and hanging wires should be avoided; in circumstances where the adoption of these precautions is not possible, bespoke armoured solar cable (e.g. single core anti-rodent armour and steel wire braid PV cable) should be utilised.
- 5.7.10 DC cable is waterproof for a duration but is not designed to lie in water for long periods, so cable runs should avoid this. This includes cables running within PV mounting framing extrusions, and cables lying on flat roofs, where water pooling can occur.
- 5.7.11 All low voltage AC cabling should be installed in accordance with BS EN 7671 and the current amendments.
- 5.7.12 The inclusion of key strategic spares at the time of installation should be considered to avoid the use of more available but inappropriate alternatives.
- 5.7.13 Outdoor DC/AC isolators should have correctly torqued bottom entry glanded cabling.



Figure 5.7.1 Module installation nearing completion (Reproduced by kind permission of Chris Roberts, Clean Energy Consulting Ltd)

## 5.8 Inspection

- 5.8.1 The requirements for a PV system inspection are outlined in BS EN 62446-1:2016 *Photovoltaic (PV) systems – requirements for testing, documentation and maintenance. Grid connected systems – documentation, commissioning tests and inspection.*
- 5.8.2 With larger projects becoming prevalent in both volume and size, the likelihood of engagement of subcontractors for delivery increases. The supply of balance-of-system components (DC cable, PV connectors, DC isolators) is often the subcontractor's responsibility, so checks should be made to verify the supply chain sourcing and ensure the components' quality meets the requirements of the design.
- 5.8.3 The PV project should be inspected at various stages during its installation. Once modules are positioned, a full inspection is not always possible. This makes it difficult to identify many of the common issues that may cause fire and complicates corrective actions when problems are identified.
- 5.8.4 All cable routes should be checked for sharp edges, and other aspects that may damage the cable over time.
- 5.8.5 It is important to check DC connector compatibility and ratings, and the compatibility of models of all equipment components. Ratings for DC/AC isolators may not be clearly displayed on some models.
- 5.8.6 Where DC cable is exposed to UV light, the cables should be covered (shaded) to minimise fading, and insulation degradation.

## 5.9 Testing and commissioning

- 5.9.1 Testing and commissioning should be completed in line with the IET PV Code of Practice requirements and as outlined in BS EN 62446-1:2016.
- 5.9.2 Seek manufacturers' guidance for testing with MLPE (module-level power electronics) technology: each MLPE manufacturer has particular procedures, requirements, and methodologies, and the recording of commissioning test data will also vary with string testing methods.

## 5.10 Handover and documentation

- 5.10.1 Handover is the phase, after installation and commissioning, during which relevant documentation and instructions are handed over and communicated to the customer. The scope of the handover will depend on the size of the system and whether the customer will engage third party O&M contractors. Whatever the arrangements, full documentation should be provided for all systems.
- 5.10.2 The IET PV Code of Practice (handover and documentation section) provides details of requirements for documentation.
- 5.10.3 Such handover documents may well form the Health and Safety file required at handover by the Construction (Design and Management) Regulations (2015).

## 5.11 Operation and maintenance

- 5.11.1 Solar Energy UK have produced an O&M document, *Industry best practice manual 2.0: Guidelines for the operation and maintenance of rooftop solar photovoltaic systems.* This provides a comprehensive guide to best practice in terms of maintenance in the context of rooftop systems. It also recommends inspection of commercial systems at least annually by a competent person.
- 5.11.2 The IET PV Code of Practice (operation and maintenance section) provides guidelines and recommendations for general maintenance, scheduled maintenance, periodic verification, and regular inspections. The IET PV Code of Practice refers to BS EN IEC 62446-2:2020, which describes basic preventive, corrective, and performance-related maintenance requirements and recommendations for grid-connected PV systems. BS EN IEC 62446-2:2020 states, 'The more often such inspections are performed the smaller is the risk of fire. The requirements for inspections during a system's lifetime are given in this document.'



- 5.11.3 Maintenance requirements vary significantly in scale, depending on the size of the system. However, the fundamental principles are the same for all PV systems and current knowledge of the operational status of each system is key, both from an energy generation perspective and in terms of the general condition of the system. If a system is not working correctly due to a potential malfunction, there are likely to be consequent failure risks that could result in fire. Larger systems are likely to have a full-time maintenance contractor.
- 5.11.4 Solar Energy UK has worked closely with Solar Power Europe to produce an industry best practice guideline for larger scale ground mount PV systems.
- 5.11.5 The IEC Technical report IEC TR 63226:2021 states that 33% of reviewed PV fires were caused by product failure. Therefore, information and measures to identify early-stage symptoms or indications of failure are very important to minimise fire risk.
- 5.11.6 Live online monitoring and error indication messaging provide easy access to PV system operation data and errors. This is very beneficial to the day-to-day monitoring of PV systems and can provide early warning of potential problems. This applies to all systems, from domestic through to larger scale systems.
- 5.11.7 Discussion with IT departments to facilitate online monitoring should be undertaken for all installations where internet connectivity (to provide operational and error data to a monitoring station) is not already provided.
- 5.11.8 PV systems with a steeper module pitch have a greater self-cleaning effect, although they will still need periodic cleaning (frequency based on risk assessment). At lower pitches, a scheduled cleaning programme should be implemented. In addition to impact on yield, films of ingrained dirt can build up at the base of each panel and may cause long term damage due to overheating of the affected PV cells. Over time, this may cause damage to the insulation properties of the PV modules, which may lead to potential module failure and fire.
- 5.11.9 A major issue for PV modules is bird droppings, which will adhere to the modules irrespective of angle. Bird droppings, more so than dust deposits, cause partial shading on individual PV cells, leading to hot spots; such hot spots have been known to develop into faults leading to fire. Insurers expect a regular cleaning programme for all commercial PV installations, carefully planned to suit the needs of each individual array (5.11.8).
- 5.11.10 Systems should only be cleaned by personnel who have knowledge of the inherent risks associated with panel cleaning and a robust approach to the mitigation of such risks. Window cleaners may have the correct equipment necessary for panel cleaning but are likely to lack knowledge of the fire and electrocution risks associated with this task. All solar panel cleaning companies should train their staff specifically for this task, have a detailed risk assessment method statement (RAMS), and hold suitable liability insurance.
- 5.11.11 IEC 62446-2:2020 recommends the routine testing of insulation resistance (Riso). The routine testing of string series resistance is recommended to help identify early signs of resistance variance/increase. PV string resistance variance/increase can lead to heating of connectors or other components, with consequential potential for arcing. IEC 62446-2:2020 states, 'Properly specified and installed PV connectors generally do not lose connection integrity but failures in these connections are one of the leading causes of series-arc related failures and fires in PV systems.'
- 5.11.12 Infrared (IR) thermography has been extensively used on larger rural-located PV systems for a number of years. It is a cost-effective way to determine PV module health. Where safe roof access is not possible, then UAVs (unmanned aerial vehicles) equipped with thermal imaging cameras can be used. Civil Aviation Authority regulations govern UAV use in the UK regulations; UAVs with a mass of 250 g or less can be used in most locations, with correct certification.

- 5.11.13 With changing weather patterns, and wetter and sunnier summers, vegetation can grow very fast in the summer months. As a consequence, vegetation growth can enter electrical equipment and cover PV modules in a relatively short space of time. Regular inspection and reactive vegetation clearance are essential.
- 5.11.14 After a storm or extreme weather event, PV systems should be inspected for damage.

#### **5.12 Corrective measures after a fire (from IEC TR 63226:2021)**

- 5.12.1 If there has been a PV fire, the recommended first step is to turn off the system at all isolation points and establish exclusion zones around uncontrolled parts of the PV installation, as parts of the system may remain vulnerable to reignition by short-circuits or arcs of an array.
- 5.12.2 Any residual combustible material should be removed.
- 5.12.3 Competent electricians with PV knowledge should undertake a full safety inspection to bring the system into a safe state, as follows.
  - i. Shut down the system. All available shutdown procedures should be performed, with all switch-disconnectors switched to the off position.
  - ii. Apply measures for avoiding reconnection, such as locking switches open and use of warning labels (lockout-tagout).
  - iii. Undertake a visual inspection of the array. Evaluate the integrity of the insulation of cables and equipment, the fixing of PV modules and equipment, and any damage to PV equipment.
  - iv. Even if there are no visual signs of damage, perform an insulation check at all strings/sub-arrays and isolate any suspect strings identified.
  - v. Check if there are any hazardous voltages between uninsulated parts and other uninsulated parts or earth potential.
  - vi. Isolate uninsulated conductors or parts. The optimal way to safely disconnect each PV module is by disconnecting all PV module connectors.

#### **5.13 Legacy and historic systems**

- 5.13.1 Both IEC TR 63226:2021 and a report undertaken by the BRE on behalf of the UK Government, as well as almost all other relevant published documents, highlight the risk of fire from incompatible or incorrectly made DC connectors and DC isolators. The reports do not demonstrate an increase of fire risk over time, but as materials age, it is likely that poorly made or non-compatible connectors may be causal in future fires. Testing of Riso and series resistance is a relatively low-cost exercise, and mandatory routine testing requirements should be introduced to regularise the existing PV installation asset that is likely to be affected.
- 5.13.2 The ability to undertake series resistance testing is a relatively recent technological innovation, yet to be formally mandated in mainstream recognised technical standards. It does not require scaffolding to determine the health of PV systems and can help to identify where strings of PV modules may be at risk of overheating.

#### **5.14 Provisions for the Fire and Rescue Service**

- 5.14.1 Arrangements should be made to provide prompt access to the site on the arrival of the Fire and Rescue Service. Firefighters should be met by security personnel or other designated members of staff, who should have the gates or barriers open awaiting their arrival.
- 5.14.2 Externally, a clear route should be maintained to allow high reach vehicles and pumping appliances to gain suitable access to all buildings with roof mounted PV installations. Suitable turning places should also be available, as set out in Approved Document B to the Building Regulations and equivalent legislation in Scotland and Northern Ireland. Where necessary, liaison should be established with the Fire and Rescue Service.

- 5.14.3 Information should be provided for the Fire and Rescue Service at a prominent location, such as the PV installation site entrance, or at a reception/gatehouse, to include:
- i. the layout of the site, including plans of large buildings, showing the locations of the PV panels and control equipment
  - ii. the location of isolation switches for PV panels
  - iii. the location of the main electrical intake(s) and consumer units
  - iv. the location of the indicator panel for the automatic fire detection and alarm installation
  - v. details of any automatic fire suppression system(s) and the location of their controls or valves
  - vi. details of ventilation systems
  - vii. the nature and location of any hazardous substances on the premises
  - viii. contact details for staff who may need to be consulted; and
  - ix. the location of hydrants, rising mains, and other sources of water on site or nearby, for firefighting purposes.
- 5.14.4 The presence of a PV system on a building is not always obvious from ground level. 'PV on the roof' signage should be clearly visible for the Fire and Rescue Service upon arrival at the building, in particular a prominent sign measuring at least 100 mm × 100 mm displayed at the consumer units or supplier's cut-out.
- 5.14.5 In the case of large installations, firefighters should be invited to visit the premises to familiarise themselves with the property and the locations of PV panels on the site.
- 5.14.6 Where mandated for compliance within BS EN 7671 (see section 5.5.6), or due to particular client/insurance requirements for commercial PV installations, a switch (or switches) should be provided in a prominent position readily accessible to firefighters to remotely isolate the DC side of the PV system. Such 'fire service switches' (i.e. DC switch-disconnectors that isolate the lines between solar modules and inverters) help to ensure the safety of firefighting personnel. Operation of the switch should as a minimum make the DC side of the wiring inside the building voltage-free. The switch should be tested during routine maintenance, with the results being recorded. These switches should be placed in safe locations remote from the PV panel arrays and are additional to operational AC and DC isolation switches. Unless specifically required, 'fire service switches' are not required in residential properties with a single phase AC supply.
- 5.14.7 Fire personnel should disconnect PV installations from the mains electricity at the intake to render the AC side of the installation voltage-free, and operate the 'fire service switch' if installed.
- 5.14.8 Fire and Rescue Service personnel should be aware that PV panels produce a DC voltage from daylight and other light sources, including any floodlights used to illuminate the fire ground, even if the AC side of the circuit is isolated from the mains electrical supply. This continuing production of DC voltage may have to be addressed in the risk assessment undertaken before firefighting commences. In many existing installations, a DC disconnect for the DC cables on the roof is not provided.

## 6 Checklist

		Yes	No	N/A	Action required	Due date	Sign on completion
<b>6.1</b>	<b>Compliance with Fire Safety Legislation (section 5.1)</b>						
6.1.1	Has a suitable and sufficient fire risk assessment been undertaken in compliance with the Regulatory Reform (Fire Safety) Order 2005 and Fire Safety Act 2021 (or equivalent legislation in Scotland and Northern Ireland) or been reviewed following the installation of PV panels? Is the introduction of the Fire Safety Act 2021, which came into effect on 16 May 2022, fully understood?						
6.1.2-i	If required, has there been discussion with the local fire authority who would be responsible for dealing with any fire at the site?						
6.1.2-ii	Has there been discussion with the current/prospective building/site insurer?						
6.1.2-iii	Where installations are proposed on historic buildings, has specific expertise within national heritage organisations (such as English Heritage, National Trust, Historic Scotland, or CADW) been consulted?						
6.1.2-iv	Has there been any discussion as to whether the selected site/rooftop is the optimal location for the addition of a PV system, or whether another location may simplify and reduce the risks of a fire and the response in the event of a fire?						
6.1.2-v	Are the existing/proposed roofing materials non-combustible, and suitable for the addition of a PV system, with no risk that they might be compromised by stray currents or arcing?						
6.1.3-i	Would the addition of a new PV system lower the fire performance/classification of the roof?						
6.1.3-ii	If the installation is to be on a combustible/partly combustible roof, has the addition of a fire resistant covering been applied?						
6.1.4	Has the installation of a mains powered smoke alarm been considered to comply with Building Regulations, and BS 5839?						
6.1.5	Research is in process to develop a suitable UK fire test specification and standard for property protection, for PV modules. In the meantime, has a suitable assessment of fire classification of (PV modules) materials of construction and available test data been undertaken, where available (e.g. UL 1703, UL 790, PD CLC/TR 50670:2016, BS EN 61730-2:2007, ASTM E108-20a)?						
6.1.6	Has it been determined whether the addition of DC disconnection switch (fire service switch) technology and interfacing with the existing fire systems would be mandatory, good practice, or not required?						
6.1.7	Does the inverter have an arc fault circuit interrupter that is acceptable? If not fitted within the inverter, is a stand-alone arc fault interrupter required or mandatory?						
6.1.8	Have measures for supporting firefighters and first responders been given consideration, e.g., access, pathways? (See section 5.18)						
6.1.9	Has a Dangerous Substances and Explosive Atmospheres Regulations (DSEAR) assessment been undertaken when a PV panel installation is being planned in an area where a potentially explosive atmosphere may form?						

		Yes	No	N/A	Action required	Due date	Sign on completion
<b>6.2</b>	<b>Business continuity (section 5.2)</b>						
6.2.1	When equipment is being specified, has careful consideration been given to fire safety implications of a PV system that will operate at a fully or partially unattended location?						
6.2.2	Has an emergency plan been drafted to accommodate the consequences of a PV fire or a fire where the PV could be impactful?						
6.2.3	Has this emergency plan been pragmatically rehearsed by means of an annual tabletop exercise, with the results being assessed and amendments made to the plan as necessary?						
<b>6.3</b>	<b>Fire safety management (section 5.3)</b>						
6.3.1	Has a carefully planned and comprehensive fire safety management regime, with appropriate fire safety routines and accepted staff training, been put in place?						
6.3.2	Has hot work – such as welding, flame cutting, and similar activities – been avoided? If for justified reasons hot work is necessary, have appropriate permits to work been arranged?						
6.3.3	Have arrangements been made during the installation process for all waste materials to be tidied, and safely stored at the end of each working period?						
6.3.4	At the commissioning stage, has the nominated operator of the system had the function and control of the system explained to them by the installer? Have full details of the system and its operation been handed over in an appropriate format, including the key topics outlined in 5.3.4?						
6.3.5	Will the client handover process cover the location of the emergency isolation switches and the importance of regular maintenance?						
6.3.6	Have steps been taken to prevent the accumulation of windblown litter and leaves, especially around or beneath PV panels?						
6.3.7	Where appropriate, have installation technicians/engineers received suitable instruction when they arrive at the premises as to the sound of the fire alarm and the actions that they should take if hearing the alarm or discovering a fire?						
6.3.8	Has consideration been given to the possibility of deliberate fire raising from outside the building by intruders, or from within by staff?						
6.3.9	Have automatic smoke detection measures been installed in any areas inside the building in which electrical control equipment for PV panels is located?						
6.3.10	As outlined in 5.2.1, has careful consideration be given to the fire safety management implications of a PV system that will operate at a fully or partially unattended location?						
6.3.11	Has the installation of water sprinklers been reviewed and considered in the context of the building on which the PV system is/will be installed?						
6.3.12	Have steps been taken to avoid obstructions and stored materials that may reduce the level of ventilation provided for the inverters, which can produce significant heat during normal operation?						
6.3.13	Has a maintenance contract or other arrangements been established or considered?						

		Yes	No	N/A	Action required	Due date	Sign on completion
<b>6.4</b>	<b>Hazard Identification (section 5.4)</b>						
6.4.1	Building fire load – Has an impact assessment of the installation of a PV system on the overall building fire load been undertaken?						
6.4.2	Roof construction – Is the roof material fire-resistive and non-combustible, meeting Class A1/A2 s1, d0 to BS EN 13501-1?						
6.4.3	Has the impact of a chimney effect, especially on pitched roofs, been considered?						
6.4.4	Are there specific clear routes to provide safe access to the roof for servicing, maintenance, cleaning, and firefighting operations?						
6.4.5	Has high density PV coverage with restriction to firefighters' access been avoided?						
6.4.6	Increased roof loading – Is there a structural engineer's report to approve the PV installation for the building, taking into account the age of the building, the method of PV system mounting, and the avoidance of leaking roof penetrations and water pooling?						
6.4.7	Has a structural review been undertaken on ballasted systems, to avoid increased water pooling on the roof due to flexing of the roof structure?						
6.4.8	Snow and ice build-up – Has consideration been given to the potential impact of drifting snow, and ice build-up?						
6.4.9	Waste and materials – Will the PV system create opportunities for the build-up of waste debris, foliage, nesting materials, and other potential additional sources of ignition?						
6.4.10	Inclement weather damage – Has a 'one in a hundred year weather event' impact review been undertaken on the PV system, with regard to wind, torrential rain, and flooding?						
6.4.11	Theft and vandalism – Has a review been undertaken of the potential risk, and mitigation requirements, particularly at locations where there are weekend closures?						
6.4.12	Are site safety practices in place, e.g. no smoking on site, or caution with hot vehicle exhaust systems in areas with dry grass?						
<b>6.5</b>	<b>Design (Section 5.5)</b>						
6.5.1	Does the PV design provide mitigating solutions to the findings of the documented risk assessment, to minimise the risks influenced by the PV system design?						
6.5.2	Have client and contractor responsibilities under CDM regulations (2015) been clearly defined?						
6.5.3	Will the design be undertaken in accordance with the IET PV Code of Practice, MCS requirements, and good practice guidelines?						
6.5.4	Is the design team competent and sufficiently experienced to be able to design a PV solution that acceptably mitigates all the risks identified in the risk assessment, or is additional expertise required?						

		Yes	No	N/A	Action required	Due date	Sign on completion
6.5.5	RISCAuthority RC67 provides general risk control guidance for PV systems from LV up to HV. A key aspect is whether the PV system design falls within the BS EN 7671 definition of 'low voltage', as this will impact on the fire safety requirements. Has this been determined?						
6.5.6	BS EN 7671 and the Regulatory Reform (Fire Safety) Order 2005 define 'low voltage' as exceeding 'extra low voltage' but not exceeding 1000 V AC or 1500 V DC between conductors, or 600 V AC or 900 V DC between conductors and earth. If a system is not defined as 'low voltage', have the additional requirements/ mitigations been identified and considered for the design?						
6.5.7	Has the requirement for adoption or adaptation of lightning protection systems been considered, in line with RC35?						
6.5.8	Have measures including arc suppression, module inverters/power optimisers, and DC disconnection systems, been considered for incorporation into the design, in order to address the mitigation requirements?						
6.5.9	Have equipment ratings been considered in order to minimise the risk of product failure over the expected design life of the system, and not the equipment warranty period alone?						
6.5.10	Have the PV arrays been designed so they do not traverse fire barriers or fire walls? Is all cabling sealed or contained in order to prevent the spread of fire across fire barriers?						
6.5.11-i	Components of PV systems with combustible elements (e. g. cables) should not be passed over a compartment/fire wall. If this cannot be avoided, they should be installed in fire-resistant cable ducts and shafts. Has this been implemented in the design?						
6.5.11-ii	On roofs, there should be a minimum distance of 2.5 m between the PV modules on each side of the compartment/fire walls. A reduced distance is permitted if the potential for a fire to spread across a compartment boundary is considered low (6.5.12). Have these restrictions been carefully considered in the design?						
6.5.12	For PV installations where the potential for a fire to spread across a compartment boundary is considered low, a minimum 1.2 m separation between the PV modules on each side of the compartment/fire wall is recommended. If this reduced separation is used, has the risk assessment – which designated the risk of fire spread as low – been carefully undertaken?						
6.5.13	Have cable routes and containment been given careful consideration? Have mitigation measures been put in place to manage DC cable routes within the building that could pose a risk to firefighters in the event of a fire?						
6.5.14	Has the internal DC cable route length been minimised where possible? Where cables are within a building and could still be live, is there appropriate mechanical protection?						
6.5.15	Have additional anti-arcing measures been considered if the roofing material is not arc resistant?						
6.5.16	Has consideration been given to in the PV system design the potential impact of rodents, nesting birds, and other animals that can cause harm and alter the fire safety properties of a PV system? (See also 6.7.9)						
6.5.17	Has the location of the PV inverters and balance-of-system electrical equipment been given careful consideration? (Typically, around 3% of inverter conversion efficiency losses are converted to heat.)						

		Yes	No	N/A	Action required	Due date	Sign on completion
6.5.18	Has the use of DC isolators been avoided where this functionality is within the PV inverter?						
6.5.19	Has section 5.3.9 and the guidance in the IET PV Code of Practice been reviewed regarding the adoption of fire detection?						
<b>6.6</b>	<b>Procurement (Section 5.6)</b>						
6.6.1	Has a process for the procurement of the PV system been established? Has an appropriate organisation to undertake the installation and operation been selected?						
6.6.2	Has the complexity of the project been reviewed, and potential providers been selected in the context of those complexities?						
6.6.3	Has MCS001-1 The MCS Contractor Standard been reviewed, as a comprehensive list of requirements for appropriate contractors?						
6.6.4-i	Does the proposed installation contractor hold an MCS Certification in PV Systems and 9001:2015?						
6.6.4-ii	Is the proposed installation contractor an SSIP (Safety Systems in Procurement) registered member of an organisation, e.g. Acclaim or CHAS?						
6.6.4-iii	Does the proposed installation contractor hold appropriate certification accreditation and competence for DC, low voltage AC and high voltage systems?						
6.6.4-iv	Does the proposed installation contractor hold environmental scheme certification (e.g. ISO 14001:2015) and have membership of safety schemes (e.g. ISO 45001:2018)(desirable)?						
6.6.4-v	Does the proposed installation contractor hold appropriate insurance including an appropriate level of professional indemnity to cover the scope of the project requirements?						
6.6.5	Has the contractor's previous relevant experience been reviewed, and references from previous customers obtained?						
6.6.6	Has a review of the key staff been undertaken, in terms of experience, competence, and suitability for the project?						
6.6.7	Has a company financial review been undertaken?						
6.6.8	Has a review of the proposed subcontractors been undertaken, including the longevity of relationships with the lead contractor/installer? Has it been determined what material/equipment will be supplied by the lead contractor or novated to the subcontractors?						
6.6.9	Will all equipment to be provided comply with the relevant UK and international technical standards? Are all PV modules MCS certified?						
<b>6.7</b>	<b>Installation (Section 5.7)</b>						
6.7.1	Has the installation been undertaken in accordance with the requirements of MCS and the IET PV Code of Practice?						
6.7.2	Has the installation been undertaken in accordance with the PV system design?						



		Yes	No	N/A	Action required	Due date	Sign on completion
6.7.3	Have manufacturer's installation instructions been carefully read and followed, including instructions for DC connectors and isolators as well as inverters and PV modules?						
6.7.4	Has mixing of PV DC connectors from different manufacturers been avoided? Do all PV DC connectors use the correct connector, assembled and installed according to the manufacturer's guidelines?						
6.7.5	Have interim DC cable inspections taken place, to prevent (for example) cable pinching beneath PV modules, and to ensure connectors are compatible?						
6.7.6	Have the DC connectors been arranged to lie horizontally, and to avoid water ingress?						
6.7.7	Are all DC cable runs on secured and supported cable management systems, with facility for water draining? Is connector orientation well managed?						
6.7.8	Is the PV modules' interconnecting cable management arranged to avoid inter-module connecting cables sagging, flapping, or lying in areas where there may be a risk of pooling water?						
6.7.9	Has mitigation been put in place to avoid damage to cables by rodents and other animals?						
6.7.10	Are DC cable runs arranged to prevent cables from lying in water for long periods?						
6.7.11	Is all low voltage AC cabling installed in accordance with BS EN 7671 and the latest amendments?						
6.7.12	Have key strategic spares been considered at the time of installation to avoid the use of inappropriate alternatives at a later time?						
6.7.13	Are cables from DC and AC isolators bottom entry, and has top entry cabling been avoided?						
<b>6.8</b>	<b>Inspection (Section 5.8)</b>						
6.8.1	Have the requirements for the PV system inspection been undertaken in accordance with BS EN 62446-1:2016?						
6.8.2	Have checks been undertaken to verify the supply chain sourcing and ensure the quality of balance-of-system components meets design requirements?						
6.8.3	Has the PV installation been inspected at various stages of the project, to ensure correct installation and check that required remedial action has been completed?						
6.8.4	Have all cable routes been checked for sharp edges, and other aspects that may damage the cable over time?						
6.8.5	Have DC connector compatibility and ratings, and the compatibility of models of equipment components (particularly DC/AC isolators), been checked? (Ratings are not always clearly displayed on isolators.)						
6.8.6	Where DC cable is exposed to UV light, have the cables been covered to minimise fading, and insulation degradation?						
<b>6.9</b>	<b>Testing and commissioning (Section 5.9)</b>						
6.9.1	Have testing and commissioning been completed in line with the IET PV Code of Practice requirements, and as outlined in BS EN 62446-1:2016?						

		Yes	No	N/A	Action required	Due date	Sign on completion
6.9.2	Has manufacturers' guidance for testing with MLPE technology been sought? (Each MLPE manufacturer has particular procedures, requirements, and methodologies, and recording of commissioning test data will also vary with string testing methods.)						
<b>6.10</b>	<b>Handover and documentation (Section 5.10)</b>						
6.10.1	Following installation and commissioning, has an appropriate handover taken place for all systems, with all relevant documentation and instructions handed over and communicated to the customer?						
6.10.2	Has the IET PV Code of Practice (Chapter 18) been reviewed to ensure all documentation requirements have been met?						
6.10.3	Handover documents may form the Health and Safety file required at handover by the CDM Regulations (2015). Has this been checked?						
<b>6.11</b>	<b>Operation and maintenance (Section 5.11)</b>						
6.11.1	Are the Operation and Maintenance practices aligned with the Solar Energy UK document, Industry best practice manual 2.0: Guidelines for the operation and maintenance of rooftop solar photovoltaic systems?						
6.11.2	Have the following documents been reviewed in terms of guidelines and recommendations for basic preventive, corrective, and performance related maintenance requirements: the IET PV Code of Practice (operation and maintenance section) and IEC 62446-2:2020?						
6.11.3	The fundamental principles of maintenance are the same for all PV systems, and current knowledge of the operational status of each system is key. Do operation and maintenance personnel have (or have access to) good system performance knowledge?						
6.11.4	Solar Energy UK has worked closely with Solar Power Europe to produce an industry best practice guideline for larger scale ground mount PV systems. Are the recommendations in this document followed where appropriate?						
6.11.5	The IEC Technical report IEC TR 63226 states that 33% of reviewed PV fires were caused by product failure, so information and measures to identify early-stage symptoms or indications of failure are very important to minimise fire risk. Are early-stage indications of failure reviewed?						
6.11.6	Are there systems for live online monitoring and error indication messaging, providing easy access to PV system operation data and errors?						
6.11.7	Has there been discussion with IT departments to facilitate online monitoring for all installations where internet connectivity (providing operational and error data to a monitoring station) is not already provided?						
6.11.8	Is a scheduled cleaning regime in place for all PV systems? (PV systems with a steeper module pitch have a greater self-cleaning effect but will still need to be cleaned periodically (frequency based on risk assessment).)						
6.11.9	A major issue for PV modules is bird droppings, which will adhere to the modules irrespective of angle. Is the cleaning regime adequate to remove bird droppings?						
6.11.10	Are cleaning personnel trained and competent, with knowledge of the inherent risks associated with panel cleaning and a robust approach to the mitigation of such risks?						

		Yes	No	N/A	Action required	Due date	Sign on completion
6.11.11	Is regular insulation resistance (Riso) testing undertaken, as recommended by BS EN IEC 62446-2:2020? The routine testing of string series resistance can help to identify early signs of resistance variance/increase.						
6.11.12	Has infrared (IR) thermography been considered as part of the O&M offering?						
6.11.13	Are regular inspections and reactive vegetation clearance undertaken to prevent overgrowing of PV modules?						
6.11.14	After a storm or extreme weather event, are PV systems inspected for damage?						
<b>6.12 Corrective measures after a fire (Section 5.12)</b>							
6.12.1	If there has been a PV fire, have all isolation points been turned off and an exclusion zone established?						
6.12.2	Has any residual combustible material been removed?						
6.12.3	Have competent engineers/technicians undertaken a full safety inspection to bring the system into a safe state?						
<b>6.13 Legacy systems (Section 5.13)</b>							
6.13.1	Both IEC TR 63226:2021 and a report undertaken by the BRE on behalf of the UK Government, as well as almost all other relevant published documents, highlight the risk of fire from incompatible or incorrectly made DC connectors and DC isolators. Are series resistance and Riso tests undertaken to check the health of all such connectors?						
6.13.2	Has series resistance testing been considered as part of the O&M offering?						
<b>6.14 Provisions for the Fire and Rescue Service (Section 5.14)</b>							
6.14.1	Have arrangements been made to provide prompt access to the site on the arrival of the Fire and Rescue Service?						
6.14.2	Has a clear maintained route been established, to allow high reach vehicles and pumping appliances to gain suitable access to all buildings with roof mounted PV installations? Are suitable turning places available?						
6.14.3	Is information for the Fire and Rescue Service provided at a prominent location?						
6.14.4	Where PV systems on a building are not obvious from ground level, is there 'PV on the roof' signage, clearly visible for the Fire and Rescue Service on arrival. The presence of a PV system on a building is not always obvious from ground level. 'PV on the roof' signage should be clearly visible for the Fire and Rescue Service upon arrival at the building, in particular a prominent sign measuring at least 100 mm x 100 mm displayed at the consumer units or supplier's cut-out?						
6.14.5	With large installations, have firefighters been invited to visit the premises to familiarise themselves with the site and the locations of PV panels?						
6.14.6	If required (for compliance with BS EN 7671, or to meet client/insurer requirements for commercial PV installations), has a 'fire service switch' been provided in a prominent position, readily accessible to firefighters, to isolate the DC side of the PV system to ensure the safety of firefighting personnel? If present, is this switch tested during routine maintenance, with the results being recorded.						

		Yes	No	N/A	Action required	Due date	Sign on completion
6.14.7	Is a method to render the AC side of the installation voltage-free available to firefighters?						
6.14.8	Are Fire and Rescue Service personnel aware that PV panels produce DC current from daylight and other light sources, including any floodlights used to illuminate the fire ground, even if the AC side of the circuit is isolated from the mains electrical supply? Has this risk been assessed?						

# Appendix 1 Principal Sector Technical Standards and guidelines

## A1.1 Principal reference documents

- A1.1.1 Globally, there is a significant number of technical standards and publications relevant to the correct design, installation, commissioning, and maintenance of PV systems in the context of fire. In 2017, BRE completed a comprehensive literature review for the UK Government: P100874-1000 *Issue 3.4 Fire and Solar PV Systems - Literature Review*. This identified 185 published technical papers on PV fires and summarised all relevant UK and international equipment and installation standards from BSI, IEC, UL, ASTM, DIN and VDE, plus the known relevant UK training courses covering aspects of PV and fires. Since that date, a significant number of additional documents and publications have been issued. A degree of centralisation is necessary to facilitate consistency and alignment with UK legislation and UK technical standards.
- A1.1.2 This document references guidelines written in the context of the UK PV sector, with contribution from UK industry standards, incorporating the relevant international standards that form the basis of, or supplement these standards..
- A1.1.3 All these documents and publications are maintained by sector expert led technical committees, and continuously updated in line with learning, innovation, and other developments. Adherence to these standards, recommendations, and guidelines is considered the best way to manage and minimise the risk of fire and to keep the RC62 standard in line with current best practice. These standards are an essential technical reference resource.

## A1.2 Microgeneration Certification Scheme (MCS) Standard MIS3002

- A1.2.1 MCS is a standards organisation that defines and maintains standards allowing the certification of small-scale renewable products, installers, and their installations. The certification scheme is associated with these standards and run on behalf of MCS by certification bodies who hold UKAS accreditation to ISO 17065. MCS certifies low-carbon products and installations used to produce electricity and heat from renewable sources. MCS is a mark of quality. Membership of MCS demonstrates adherence to these recognised industry standards, highlighting quality, competency, and compliance.
- A1.2.2 For PV, the definition of microgeneration is up to 50 kWp. However, as PV is modular, many aspects of the standard are generally relevant for systems larger than 50 kWp when fire management is considered in context.
- A1.2.3 In September 2006, DTI(BEIS) awarded BRE Global a contract to develop MCS, and the scheme was introduced in 2007 with installer and product standards for the suite of microgeneration technologies including PV. MIS3002 is the relevant MCS PV installation standard and has been upgraded on a continuous basis since inception. In September 2020, version 4 of the MIS3002 standard was published; this, with some modifications, aligned with the IET PV Code of Practice.
- A1.2.4 As the overarching reference standard, the IET PV Code of Practice covers both microgeneration and larger PV projects.

## A1.3 IET PV Code of Practice

- A1.3.1 The Institution of Engineering and Technology (IET) is a multidisciplinary professional engineering institution. The IET originates from an amalgamation of institutions dating back to 1871, and is one of the most established engineering institutions globally. The IET also jointly publishes BS EN 7671, also known as the 'Electrical Regulations'.

- A1.3.2 The IET PV Code of Practice, first published in 2015 and republished in 2022, sets out the requirements for the design, specification, installation, commissioning, operation, and maintenance of grid-connected solar PV systems installed in the UK. It aims to ensure safe, effective, and competently installed PV systems.
- A1.3.3 The IET PV Code of Practice is primarily intended for use by PV system designers and installers, developers, and operators, responsible for the safe and effective design, installation and operation of PV systems. The IET PV Code of Practice is maintained, reviewed, and upgraded on an ongoing basis.

#### **A1.4 IEC (International Electrotechnical Commission)**

- A1.4.1 IEC is an international standards organisation that prepares and publishes international standards for all electrical, electronic, and related technologies. IEC standards cover a vast range of technologies, including solar energy. The IEC also manages global conformity assessment systems that certify whether equipment, systems, or components conform to its international standards.
- A1.4.2 In 2016 and 2020, IEC published two key associated standards: BS EN IEC 62446-1:2016 *Photovoltaic (PV) systems – Requirements for testing, documentation and maintenance. Part 1: Grid connected systems – Documentation, commissioning tests and inspection*, and BS EN IEC 62446-2:2020 *Photovoltaic (PV) systems – Requirements for testing, documentation and maintenance – Part 2: Grid connected systems – Maintenance of PV systems*.
- A1.4.3 In 2021, the IEC published a report IEC TR 63226 *Managing fire risk related to photovoltaic (PV) systems on buildings*. This is a focused technical report on rooftop PV fires.

#### **A1.5 Solar Energy UK – Operation and maintenance best practice**

- A1.5.1 Solar Energy UK (SEUK) is the most established (1978) trade association working for and representing the entire solar and energy storage value sector.
- A1.5.2 In 2020, SEUK published their *Industry best practice manual 2.0: Guidelines for the operation and maintenance of rooftop solar photovoltaic systems*. This document provides a comprehensive guide as to what is good practice in terms of maintenance in the context of rooftop systems.
- A1.5.3 Solar Energy UK has worked closely with Solar Power Europe to produce an industry best practice guideline for larger scale ground mount solar PV systems: *Operation & Maintenance Best Practice Guidelines: Version 5.0*.

# Appendix 2 PV system components and electrical fires

## A2.1 Background

- A2.1.1 PV systems comprise a number of system components that are common in all PV system installations. These are PV modules, mounting systems, connectors, cabling, isolators, power conversion/inverters, and switchgear. Larger systems may have a high voltage system and use HV equipment, including switchgear and transformers.
- A2.1.2 The fundamental causes of most electrical fires relate to heating, arcing, and induced currents produced by electrical systems, which can cause materials – both metallic and non-metallic – to combust.

## A2.2 Historical findings

- A2.2.1 A technical report published by the IEC in February 2021 – IEC TR 63226:2020 *Managing fire risk related to photovoltaic (PV) systems on buildings* – outlined the four primary causes of PV system fires where the likely cause was identified.
- A2.2.2 The findings were based on investigation of a statistically meaningful 110 fires and provide a clear indication that managing fire risk covers a broad range of issues. Installation and product defect faults account for 72% of the causal factors for fire (see Figure A2.2.1).

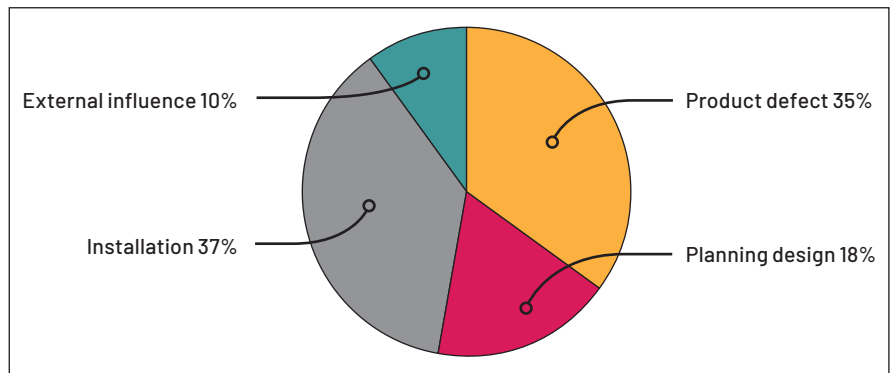

Figure A2.2.1 Primary fire causes (Source: IEC TR 63226: Managing fire risk related to photovoltaic (PV) systems on buildings)

- A2.2.3 An analogous UK study, undertaken in 2017 by the BRE and submitted to Government, investigated the PV components most likely to develop faults that led to a fire incident. Their results, based on investigation of 46 incidents, are shown in Figure A2.2.2.

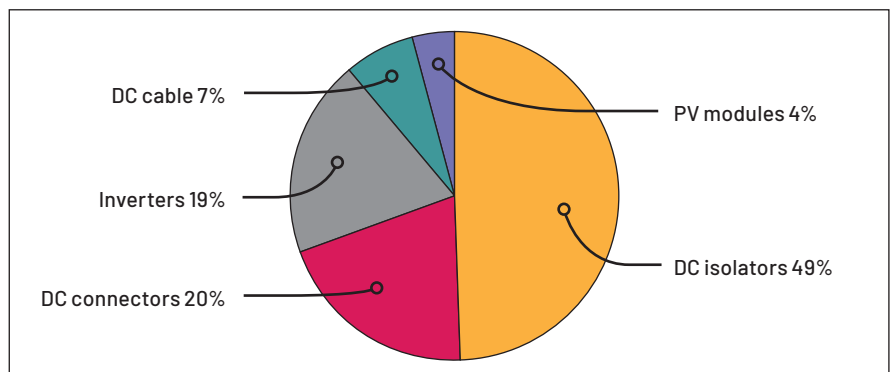

Figure A2.2.2 PV system component faults as causes of fire (Source: P100874-1004 Issue 2.5 Fire and Solar PV Systems – Investigations and Evidence)

## Appendix 3 PV system components (principal)

### A3.1 PV module/laminate

- A3.1.1 PV modules are typically made of a thin layer of semi-conducting material between a sheet of glass and a polymer resin/glass backing. When exposed to daylight, the semi-conducting material produces electricity. Each PV panel typically covers an area of 1.7-2.5 m<sup>2</sup>, depending on the manufacturer, and typically produces about 300-500 watts of peak DC power. There are four basic types of PV panel: monocrystalline, polycrystalline (or multicrystalline), hybrid, and amorphous silicon. All are made from silicon but there are differences in the way the silicon is cut and treated. Typical monocrystalline/polycrystalline based modules – which, to date, have been the most prevalent in the UK – consist of 60-72 full cells or 120 × 144 half cells, electrically soldered together in a series configuration in the module manufacturing facility. There are other existing and emerging PV technologies available that vary from the mainstream, module based configuration.

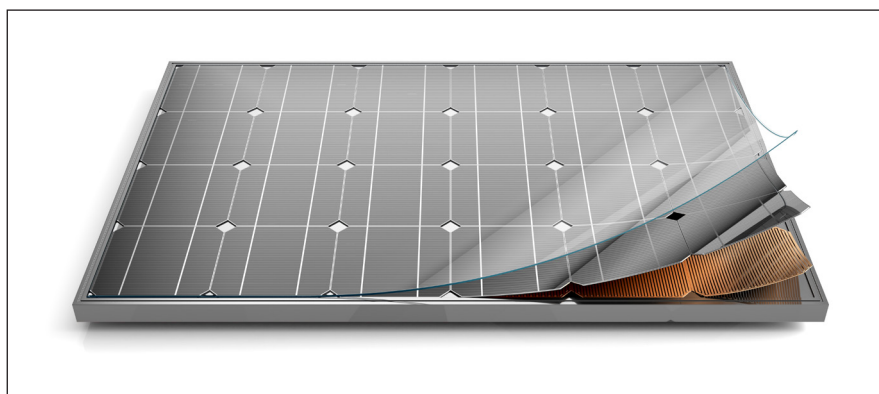

Figure A3.1.1 Typical PV module layers. Actual layer materials vary (Source: Getty/larenenko)

### A3.2 PV cable

- A3.2.1 PV cable is a bespoke product for PV systems. It is typically flexible, multi-stranded, double-insulated protected cable, used to connect the PV strings to the inverter; it can be in lengths from a few metres to several hundred metres. PV cable is typically non-armoured, so routes should be mechanically sound and free from aspects that can damage and lower the insulation integrity and increase the risk of earth faults or arcing. DC cable is water resistant but continuous immersion in water will lower the insulation strength.

### A3.3 PV DC connectors

- A3.3.1 PV connectors are a critically important part of a PV system, used to mate DC cables from PV modules to cable to connect to the inverters. They are recognised as one of the most common causal factors of PV fires. PV connectors require correct 'making', with correct cable-to-pin crimping using the correct crimping tool, correct torquing of the gland for IP integrity, and connector compatibility. Connector compatibility is essential: there is a large number of low-cost clones that are very difficult to distinguish from the recognised brands provided by reputable module and inverter manufacturers, but non-compatibility may lead to water/moisture ingress and/or bimetallic corrosion (whereby differing metal alloys in continual contact lead to connector heating and alteration to connector shape, also leading to water/moisture ingress and increased risk of arcing).
- A3.3.2 Correctly made and located PV connectors are reliable, but non-compliant connectors will compromise the integrity of the connection.



- A3.3.3 Regular testing of insulation and series resistance is an expedient way to determine PV system connector health and to identify underlying or emerging issues that could be indicative warnings of increased fire risk.

#### A3.4 DC isolator

- A3.4.1 DC isolators isolate the PV string from the inverter. They are designed to isolate both the positive and negative PV strings under load and can accommodate significant arcing at the point of making or breaking the circuit when operational. DC cable typically connects to a DC isolator with screw terminal connections; these connections are subject to daily thermal cycling and, as the copper conductor is malleable, can work loose over time causing arcing. Outdoor located DC isolators should have correctly torqued bottom entry glanded cabling.
- A3.4.2 It is essential to select the correct DC isolator voltage and current rating, and to use a DC isolator rather than an AC isolator. The specification of reputable manufacturers is important; although larger PV systems generally have the DC isolation function within the inverter, this does not change the function of the DC isolator. Lack of adherence to correct specification and installation can significantly increase the risk of fire.

#### A3.5 PV combiner box

- A3.5.1 On larger PV systems with multiple PV strings, PV combiner boxes are often used to merge the multiple PV inputs of up to 40 strings (400 A) into one DC +/- cable pair feeding the inverter. A PV combiner box typically comprises multiple screw or connector terminations, fuses, and a large DC switch to simultaneously isolate the DC - and +. PV combiner boxes are often located externally on PV farms and require IP protection from moisture and water ingress, as well as from dust and insects. PV combiner boxes are more susceptible to fire risk than other components, due to the potential large number of screw terminations and high DC currents at the point of making/breaking, with some inevitable arcing when the switch is opened/closed.

#### A3.6 Inverter

- A3.6.1 The PV inverter is the core of a PV system; it converts the DC to AC power, and generally provides monitoring data on DC and AC performance. Inverters can be indoor or outdoor rated, and contain power electronic componentry and microprocessor software-based control. At peak operation, the power conversion is around 97% efficient; the losses are typically converted into heat, which is dissipated via external heatsinks or internal heatsinks with fans. Good ventilation and regular cleaning of cooling fans/filters are essential to maintain correct operation, especially in dusty environments. It is likely that the inverter will need replacement during the life of a PV system. Most PV inverters use high speed IGBT (insulated-gate bipolar transistor) switching to convert DC to AC power; the IGBT board will be the hardest working system, most likely to be the critical point of failure in an inverter.
- A3.6.2 Power conversion from DC to AC can be via module based micro inverters, DC string inverters, power optimisers/inverters, and larger centralised inverters.

#### A3.7 Mounting systems

- A3.7.1 All PV systems require the panels to be secured to a roof, or to the ground, with a mounting system. The mounting system must hold the PV modules securely in place in the most extreme conditions that may be expected. The structural elements of a PV system are important, and all systems - whether fixed or ballasted - should be structurally acceptable and subject to a full structural engineer's analysis, to ensure that roof stability has not been compromised and that there is no roof deflection (which will lead to additional roof loadings from rain and snow).

A3.7.2 With acceptance that weather patterns are changing, the installation needs to be designed for the worst wind-speed case, with any necessary wind deflectors correctly installed.

A3.7.3 Suitable references include BS EN 1990:2002+A1 *Eurocode: Basis of structural design* and BRE DG 489 *Wind loads on roof-mounted photovoltaic and solar thermal systems*.

### A3.8 Monitoring and telemetry systems

A3.8.1 Many PV systems have monitoring systems, providing information from kWh generation through to AC and DC string/module parameters, Riso, and event recording. Good telemetry data is a good platform for providing insight into system performance characteristic changes that may be symptomatic of PV system concerns.

### A3.9 HV transformers and switchgear

A3.9.1 Larger PV systems are often connected to the grid at HV/EHV (11 kV to 132/275/400 kV). To increase the voltage to facilitate grid connection, additional transformers, isolation, and switchgear are required. Transformers are typically oil/synthetic oil or air cooled. Transformers operate at maximum operational duty when in peak sunshine.

## Appendix 4 References

(\*including relevant texts not explicitly mentioned in the body of this guide.)

### A4.1 Legislative

- A4.1.1 Fire Safety Act 2021, UKGPA 2021 c. 24
- A4.1.2 The Regulatory Reform (Fire Safety) Order 2005, UKSI 2005 No. 1541
- A4.1.3 The Fire (Scotland) Act 2005, asp 5
- A4.1.4 The Fire Safety (Scotland) Regulations 2006, SSI 2006 No. 456
- A4.1.5 The Fire and Rescue Services (Northern Ireland) Order 2006, NIOC No. 1254 (N.I. 9)
- A4.1.6 The Fire Safety Regulations (Northern Ireland) 2010, NISR 2010 No. 325
- A4.1.7 The Dangerous Substances and Explosive Atmospheres Regulations (DSEAR) 2002 (as amended 2015), UKSI 2002 No. 2776
- A4.1.8 Approved Document B to the Building Regulations 2000: Fire safety
- A4.1.9 Approved Document B to the Building Regulations 2010: Fire safety – Volume 1: Dwellings (2019, amended 2020 and 2022)
- A4.1.10 Approved Document B to the Building Regulations 2010: Fire safety – Volume 2: Buildings other than dwellings (2019, amended 2020 and 2022)
- A4.1.11 Building (Scotland) Act 2003 (asp 8)
- A4.1.12 The Building Regulations (Northern Ireland) 2012 No 192
- A4.1.13 Building Regulations and Fire Safety Procedural Guidance, July 2020\*
- A4.1.14 The Electrical Safety Standards in the Private Rented Sector (England) Regulations 2020\*
- A4.1.15 The Electricity at Work Regulations 1989\*
- A4.1.16 Health and Safety at Work etc. Act (HASAWA) 1974\*
- A4.1.17 The Electricity Safety, Quality and Continuity Regulations (ESQCR) 2002\*
- A4.1.18 Construction (Design and Management) Regulations 2015

### A4.2 RISC Authority

- A4.2.1 *Business resilience: A Guide to Protecting Your Business and Its People*, 2005, Fire Protection Association
- A4.2.2 The ROBUST software (Resilient Business Software Toolkit) is available at <https://www.thefpa.co.uk/advice-and-guidance/public-toolkits/robust-business-continuity-software>
- A4.2.3 *RC7 Recommendations for hot work*, 2013, Fire Protection Association
- A4.2.4 *RC35 Protection of buildings against lightning strike*, 2013, Fire Protection Association
- A4.2.5 *RC42 Fire safety of unattended processes*, 2010, Fire Protection Association
- A4.2.6 *RC48 Arson prevention: The protection of premises from deliberate fire raising*, 2010, Fire Protection Association
- A4.2.7 *RC61 Recommendations for the storage, handling and use of batteries*, 2014, Fire Protection Association\*
- A4.2.8 *RC62 Recommendations for fire safety with photovoltaic panel installations*, 2016, Fire Protection Association
- A4.2.9 *RC67 Recommendations for electrical safety in the event of fire*, 2018, Fire Protection Association
- A4.2.10 *Hot Works Site Induction Toolkit*, RISC Authority
- A4.2.11 *BDM01 A to Z of Essential Principles for the protection of buildings*, 2022, Fire Protection Association
- A4.2.12 *S33 Solar farm security*, 2020, RISC Authority
- A4.2.13 *RISC Authority Need to Know Guide RE1: Battery Energy Storage Systems (BESS) – Commercial Lithium-ion Battery Installations*

### A4.3 Electrical and PV sector specific

- A4.3.1 MIS3002 *The Solar PV Standard (Installation), Issue 4.0, 2020, MCS*
- A4.3.2 MCS001-1 *The MCS Contractor Standard – Part 1: Requirements for MCS Contractors, Issue 4.1, 2020, MCS*
- A4.3.3 MCS001-2 *The MCS Contractors Standard – Part 2: The Certification Process, Issue 4.2, 2020, MCS*
- A4.3.4 MCS005 *Product Certification Scheme Requirements: Solar Photovoltaic Modules, Issue 3.0, 2018, BEIS\**
- A4.3.5 MCS012 *MCS Product Certification Scheme Requirements: Pitched Roof Installation Kits, Issue 2.4, 2019, MCS\**
- A4.3.6 *Briefing: MCS012 and the Fire Performance of Pitched Roof Mounted Solar Systems, Issue 1.1, 2019, MCS\**
- A4.3.7 *IET Code of Practice for Grid-connected Solar Photovoltaic Systems (2nd edition), 2022, IET*
- A4.3.8 *IET Code of Practice for In-service Inspection and Testing of Electrical Equipment (5th edition), 2020, IET\**
- A4.3.9 BS EN 13501-1-2018 *Fire classification of construction products and building elements – Classification using data from reaction to fire tests, 2019, BSI*
- A4.3.10 BS EN IEC 61215-1:2021 *Terrestrial photovoltaic (PV) modules. Design qualification and type approval – Test requirements, 2021, BSI\**
- A4.3.11 BS EN 62446-1:2016 *Photovoltaic (PV) systems – Requirements for testing, documentation and maintenance. Grid connected systems – Documentation, commissioning tests and inspection, 2016, BSI*
- A4.3.12 BS EN IEC 62446-2:2020 *Photovoltaic (PV) systems – Requirements for testing, documentation and maintenance – Part 2: Grid connected systems – Maintenance of PV systems, 2020, BSI*
- A4.3.13 IEC 62548:2016 *Photovoltaic (PV) arrays – Design requirements, 2016, IEC*
- A4.3.14 IEC 60364-7-712:2017 *Low voltage electrical installations – Part 7-712: Requirements for special installations or locations – Solar photovoltaic (PV) power supply systems, 2017, IEC*
- A4.3.15 IEC TS 62738:2018 *Ground-mounted photovoltaic power plants – Design guidelines and recommendations, 2018, IEC\**
- A4.3.16 IEC 62852:2014+AMD1:2020 (Consolidated version) *Connectors for DC-application in photovoltaic systems – Safety requirements and tests, 2020, IEC\**
- A4.3.17 IEC TR 63225:2019 *Incompatibility of connectors for DC-application in photovoltaic systems, 2019, IEC*
- A4.3.18 IEC TR 63226:2021 *Managing fire risk related to photovoltaic (PV) systems on buildings, 2021, IEC*
- A4.3.19 IEC 63092-1:2020 *Photovoltaics in buildings – Part 1: Requirements for building-integrated photovoltaic modules, 2020, IEC\**
- A4.3.20 IEC 63092-2:2020 *Photovoltaics in buildings – Part 2: Requirements for building-integrated photovoltaic systems, 2020, IEC\**
- A4.3.21 BS EN 7671:2018+A2:2022 *Requirements for Electrical Installations. The IET Wiring Regulations, 2022, BSI*
- A4.3.22 BS 5839-6:2019+A1:2020 *Fire detection and fire alarm systems for buildings – Code of practice for the design, installation, commissioning and maintenance of fire detection and fire alarm systems in domestic premises, 2020, BSI*
- A4.3.23 ISO 9001:2015 *Quality management systems – Requirements, 2015, ISO*
- A4.3.24 ISO 14001:2015 *Environmental management systems – Requirements with guidance for use, 2015, ISO*
- A4.3.25 ISO 45001:2018 *Occupational health and safety management systems – Requirements with guidance for use, 2018, ISO*
- A4.3.26 ISO/IEC 17065:2012 *Conformity assessment – Requirements for bodies certifying products, processes and services, 2012, ISO*

- A4.3.27 UL 1703 *Standard for Flat-Plate Photovoltaic Modules and Panels*, 2022, Underwriters Laboratories Inc.
- A4.3.28 UL 790 *Standard Test Methods for Fire Tests of Roof Coverings (Building Integrated Photovoltaics products only)*, 2002, Underwriters Laboratories Inc.
- A4.3.29 PD CLC/TR 50670:2016 *External fire exposure to roofs in combination with photovoltaic (PV) arrays – Test method(s)*, 2016, BSI
- A4.3.30 BS EN 61730-2:2007+A1:2012 *Photovoltaic (PV) module safety qualification – Part 2: Requirements for testing*, 2012, BSI
- A4.3.31 ASTM E108-20a *Standard Test Methods for Fire Tests of Roof Coverings*, 2020, ASTM

#### **A4.4 BS Fire detection**

- A4.4.1 BS ISO 2859-2:2020 *Sampling procedures for inspection by attributes – Sampling plans indexed by limiting quality (LQ) for isolated hot inspection*, 2020, BSI\*

#### **A4.5 Solar Energy UK and Solar Power Europe**

- A4.5.1 *Industry best practice manual 2.0: Guidelines for the operation and maintenance of rooftop solar photovoltaic systems*, 2020, SEUK
- A4.5.2 *Operation & Maintenance Best Practice Guidelines: Version 5.0*, 2021, SolarPower Europe

#### **A4.6 Building Research Establishment (BRE)**

- A4.6.1 P100874-1000 *Issue 3.4 Fire and Solar PV Systems – Literature Review*, 2017, BRE
- A4.6.2 P100874-1004 *Issue 2.5 Fire and Solar PV Systems – Investigation and Evidence*, 2017, BRE
- A4.6.3 P100874-1006 *Issue 2.5 Fire and Solar PV Systems – Recommendations for the Photovoltaic Industry*, 2017, BRE\*
- A4.6.4 P100874-1008 *Issue 2.4 Fire and Solar PV Systems – Recommendations for the Fire and Rescue Services*, 2017, BRE\*
- A4.6.5 DG 489 *Wind loads on roof-mounted photovoltaic and solar thermal systems*, 2014, BRE

#### **A4.7 Other**

- A4.7.1 CFPA-E Guideline No 37:2018 *F Photovoltaic systems: Recommendations on loss prevention*, 2018, The Confederation of Fire Protection Associations Europe (CFPA-E)
- A4.7.2 BS EN 1990:2002+A1:2005 *Eurocode – Basis of structural design*, 2002, BSI
- A4.7.3 DTI/Pub URN 06/1972 *Photovoltaics in Buildings: Guide to the installation of PV systems (2nd edition)*, 2006, DTI, , DTI

## Appendix 5 The equivalent circuit of a PV panel or string

A PV module or string of series connected PV modules can be simplified into a visual equivalent circuit, which can clearly outline the factors that may contribute to potential causes of fire. There are three resistive components of a PV string, all of which are relevant in the review of fire risk impact.

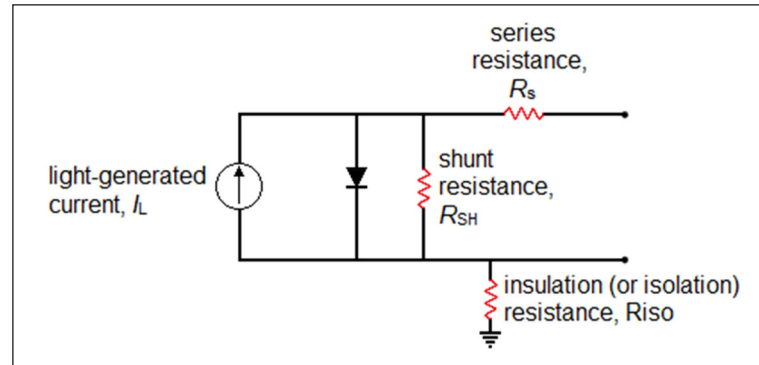

Figure A5.1 The equivalent circuit of a PV panel or string

### A5.1 Series resistance

- A5.1.1 The series resistance of a PV string system is the total electrical combined series resistance from the string ends connecting the inverter/power optimiser and the module(s). When in darkness, the PV cells have a high series resistance. In daylight, however, healthy cells have a very low resistance value – about 0.5 ohms per module – and the connectors, junction boxes, and cable add a low but insignificant resistive value.
- A5.1.2 System imperfections – e.g. poor connectors or DC isolators – can increase the series resistance. The heat loss in each component is derived from  $I^2R$ , where  $R$  is the series resistance of the component. Therefore, a poor connector with a high series resistance will heat at peak current flow. Although unlikely to catch fire, the heat can be sufficient to melt/distort the connector itself, leading to a loss of water tightness, weakened insulation, and increased risk of arcing.

### A5.2 Shunt resistance

- A5.2.1 Shunt resistance principally pertains to PV modules only. Power losses caused by the presence of a shunt resistance,  $R_{SH}$ , are typically due to manufacturing defects, rather than poor system design, so can go unnoticed. Low shunt resistance causes power losses in solar systems, by providing an alternative current path for the generated current. Such a diversion reduces the amount of current flowing correctly through the solar system and thus reduces the voltage from the solar modules, lowering efficiency. This issue becomes more significant when the shunt resistance route can connect to the earth via the module frame, back sheet or glass. A lowering of PV cell shunt resistance is a common form of potential induced degradation (PID).
- A5.2.2 Typical healthy shunt resistance power losses are about 0.18% and a healthy module has a shunt resistance of about 10 k $\Omega$ .

### A5.3 Isolation/insulation resistance

- A5.3.1 Insulation resistance (sometimes referred to as isolation resistance) is the resistance from the PV DC conductive circuit to ground. A healthy Riso value is typically  $>1\text{ G}\Omega$ . If there are circuit defects – for example, if the DC cable is damaged, or if connectors are non-matching, distorted by heat or bimetallic corrosion, or subject to moisture ingress – a more conductive route can be formed to earth. This lowers the insulation resistance, increasing the risk of ground faults and, more significantly, arcing when the voltage and lower resistance are sufficient to break down the insulation.
- A5.3.2 Riso testing is a standard PV electrical test. The addition of  $R_s$  testing – which can be done from accessible PV inverters – will add significant additional knowledge of the system health. Specific shunt resistance testing is more specialised, and not easy for rooftop systems, because module access is required.
- A5.3.3 The gradient of the PV IV curve at  $V_{\text{open circuit}}$  can indicate the shunt resistance value, and at  $I_{\text{short circuit}}$  can indicate the series resistance of the PV string.

## Appendix 6 Example issues and losses

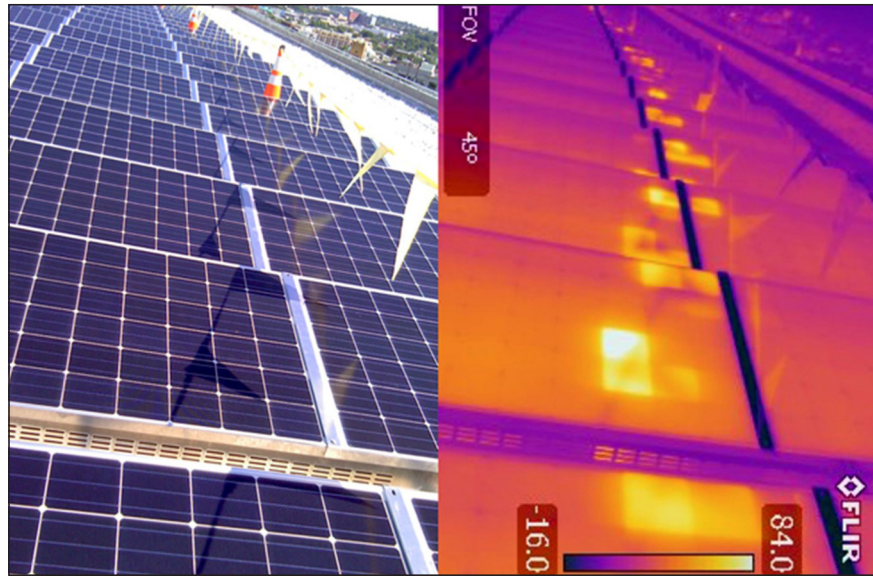

Figure A6.1 Overheating of PV cells due to shading (in this case by bunting), identified by infra-red thermography inspection (Reproduced by kind permission of William Sekulic (NREL), location Washington DC)



Figure A6.2 Solar panels before and after cleaning. Shading of solar panels due to foreign matter can lead to overheating. (Reproduced by kind permission of Helios Solar O&M)

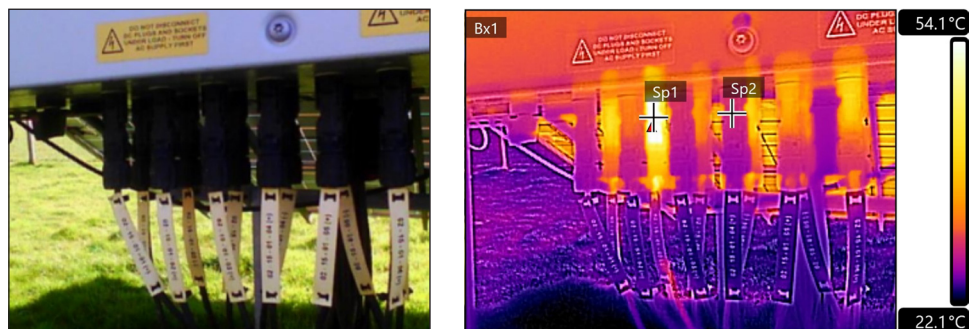

Figure A6.3 Thermographic image of inverter connectors, showing overheating. (Reproduced by kind permission of LHW Partnership LLP)





Figure A6.4 DC connector leakage. Discoloration of roof caused by leakage current, due to mis-matching connectors. (Reproduced by kind permission of Helios Solar O&M)

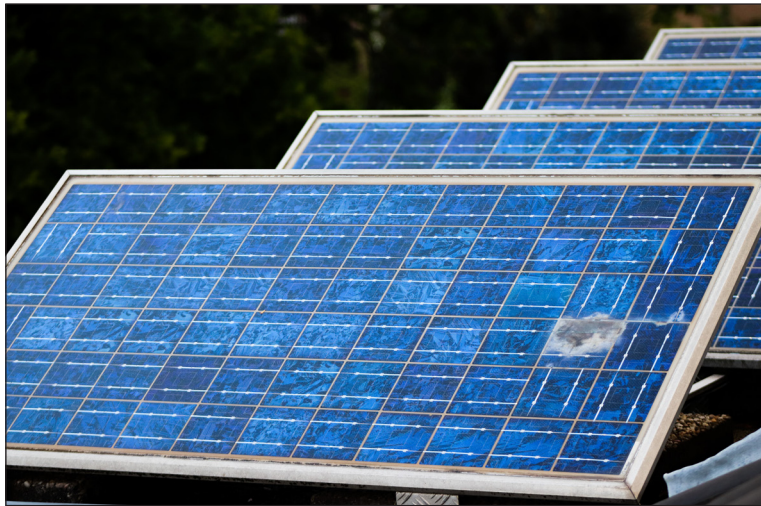

Figure A6.5 Solar panel, incipient stage damage from overheating



Figure A6.6 Solar panel fire on roof of Bristol science museum, April 2022. Due to damage, the museum will not reopen until 2023 (Source: Avon & Somerset Constabulary drone footage)



**Fire Protection  
Association®**



**Fire Protection Association**

London Road

Moreton in Marsh

Gloucestershire GL56 0RH

**T:** +44 (0)1608 812500

**E:** [info@riscauthority.co.uk](mailto:info@riscauthority.co.uk)

**W:** [www.thefpa.co.uk](http://www.thefpa.co.uk)

2023 © The Fire Protection Association  
on behalf of RISCAuthority

**RISK INSIGHT, STRATEGY AND CONTROL AUTHORITY**  
**REDUCING INSURABLE RISK THROUGH RESEARCH, ADVICE AND BEST PRACTICE**